

VISPA XS

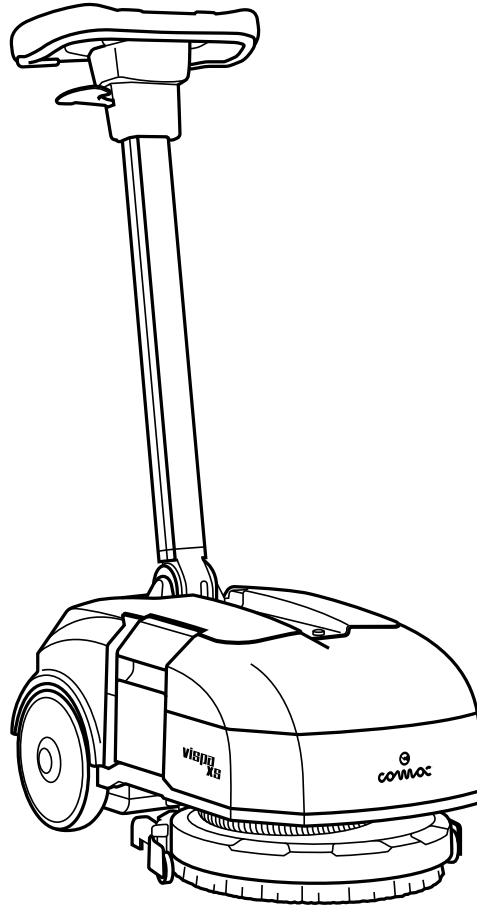

PROFESSIONAL MICRO AUTOSCRUBBER

IT CATALOGO RICAMBI
EN SPARE PARTS CATALOGUE
FR CATALOGUE DE PIECES DETACHEES

DE ERSATZKATALOG
ES CATALOGO PIEZAS DE REPUESTO



SOMMARIO

SOMMARIO.....	3
INTRODUZIONE.....	6
MODALITÀ DI ORDINAZIONE.....	6
STRUTTURA PRODOTTO.....	8
GRUPPO BASAMENTO.....	10
GRUPPO TERGIPAVIMENTO.....	12
GRUPPO COMANDO TERGIPAVIMENTO.....	14
GRUPPO TELAIO E CARROZZERIA.....	16
GRUPPO SERBATOIO.....	20
GRUPPO ASPIRAZIONE.....	22
GRUPPO IDRICO.....	24
GRUPPO MANUBRIO.....	26
GRUPPO VOLANTE DI COMANDO.....	28

SUMMARY

SUMMARY.....	3
INTRODUCTION.....	6
HOW TO ORDER.....	6
STRUCTURE OF THE MACHINE.....	8
BRUSHES BASE ASSEMBLY.....	10
SQUEEGEE ASSEMBLY.....	12
SQUEEGEE CONTROL ASSEMBLY.....	14
BODYWORK ASSEMBLY.....	16
TANK GROUP.....	20
SUCTION MOTOR ASSEMBLY.....	22
WATER UNIT.....	24
STEERING COLUMN GROUP.....	26
GROUP STEERING WHEEL CONTROL.....	28

SOMMAIRE

SOMMAIRE.....	3
INTRODUCTION.....	6
COMMENT PASSER COMMANDE.....	6
STRUCTURE DE LA MACHINE.....	8
GROUPE PLATEAU DES BROSSES.....	10
ENSEMBLE DE SUCEUR.....	12
GROUPE COMMANDE DE SUCEUR.....	14
GROUPE DE CARROSERIE.....	16
GROUPE DE RÉSERVOIR.....	20
GROUPE MOTEUR D'ASPIRATION.....	22
GROUPE HYDRIQUE.....	24
GROUPE DE PILOTAGE.....	26
GROUPE DE CONTRÔLE DU VOLANT.....	28

INHALTSANGABE

INHALTSANGABE.....	3
EINLEITUNG.....	6
BESTELLVORSCHLAG.....	7
AUFBAU DER MASCHINE.....	8
GRUPPE BÜRSTENGESTELL.....	10
SAUGFUSSGRUPPE.....	12
GRUPPE SAUGFUSSBETÄTIGUNG.....	14
GRUPPE FAHRGESTELL.....	16
TANK GROUP.....	20
SAUGMOTORGRUPE.....	22
WASSERGRUPPE.....	24
STEUERGRUPPE.....	26
GROUP LENKRAD CONTROL.....	28

ÍNDICE

ÍNDICE	4
INTRODUCCIÓN:.....	7
MODALIDADES DE LOS PEDIDOS:.....	7
ESTRUCTURA DE LA MÁQUINA	8
GRUPO BANCADA CEPILLOS	10
GRUPO LIMPIADOR DE SUELO	12
GRUPO MANDO LIMPIAPAVIMENTOS	14
GRUPO CARROCERÍA	16
GRUPO DE TANQUE.....	20
GRUPO MOTOR SUCCION	22
GRUPO AGUA	24
GRUPO DIRECTIVO.....	26
GRUPO DE CONTROL VOLANTE.....	28

IT - Le descrizioni contenute nella presente pubblicazione non si intendono impegnative. L'azienda pertanto, si riserva il diritto di apportare in qualunque momento, le eventuali modifiche ad organi, dettagli, forniture di accessori, che essa ritiene convenienti per un miglioramento o per qualsiasi esigenza di carattere costruttivo o commerciale. La riproduzione anche parziale dei testi e dei disegni, contenuti nella presente pubblicazione, è vietata ai sensi di legge. L'azienda si riserva il diritto di apportare modifiche di carattere tecnico e/o di dotazione. Le immagini sono da intendersi di puro riferimento e non vincolanti in termini di design e dotazione.

INTRODUZIONE:

Il presente vuole essere da guida per l'ordinazione delle parti di ricambio ed è stato realizzato in modo da consentire una rapida identificazione della macchina in tutte le sue versioni e quindi una rapida visualizzazione dei pezzi che la compongono.

MODALITÀ DI ORDINAZIONE:

Per facilitare la ricerca di magazzino e la spedizione dei pezzi di ricambio, si pregano vivamente i Sig. Clienti di attenersi alle seguenti norme e specificare sempre :

- Modello e numero di matricola della macchina;
- Numero di posizione e numero di tavola dove sono rappresentati;
- Codice di ordinazione e denominazione;
- Quantità dei pezzi desiderati;
- Indirizzo esatto e ragione sociale del Committente, completo con l'eventuale recapito per la consegna della merce;
- Mezzo di spedizione desiderato. (Nel caso questa voce non sia specificata la Ditta Costruttrice si riserva di usare a sua discrezione il mezzo più opportuno).

EN - The contained descriptions in the present publication are not binding. The Manufacturer therefore reserves itself the right to bring in whatever moment possible organs changes, details or supplies of accessories, that it holds convenient for an improvement, or for any demand of constructive or commercial character. The partial reproduction of the texts and diagrammes contained in the present catalog, is forbidden by law. The Manufacturer reserves itself the right to bring changes of technical character and/or of endowment. The images are meant of pure reference and not binding in terms of design and endowment.

INTRODUCTION:

This catalogue is intended to serve as a guide for the ordering of spare parts and is designed to facilitate rapid identification of the machine in all its versions and to rapid location of its component parts.

HOW TO ORDER:

For the purpose of simplifying stock searching and the delivery of spare parts, we would ask our customers to observe the following standard procedures, at all times specifying:

- The model and part number of the machine;
- The position number and the number of the table of chart in which the parts appear;

- Ordering code and part name;
- Quantity of parts required;
- Precise address and company status of the purchaser placing the order, complete with address for delivery of the goods;
- Shipping means required.

FR - Les descriptions contenu dans la présente publication ne s'entendent pas contraignant. Le Fabriquant donc, il se réserve le droit d'apporter dans n'importe quel moment, les modifications éventuelles à organes, détails, fournitures d'accessoires, qu'elle croit convenables pour une amélioration ou pour n'importe quel exigence de caractère constructif ou commercial.

La reproduction partielle aussi des textes et des dessins, contenu dans le présent catalogue, elle est prohibée aux termes de la loi. Le Fabriquant se réserve le droit d'apporter modifications de caractère technique et/ou de dotation. Les images sont à s'entendre en référence pure et pas contraignants en termes de design et dotation.

INTRODUCTION:

Le présent catalogue a pour but de guider l'utilisateur dans les commandes de pièces détachées. Il a été réalisé pour faciliter une identification rapide de la machine dans toutes ses versions et permet ainsi un repérage rapide de ses composants.

COMMENT PASSER COMMANDE:

Afin de simplifier la recherche dans le magasin et l'expédition des pièces de rechange, nous prions notre clientèle de respecter la procédure suivante en indiquant toujours:

- Le modèle et numéro de la machine;
- Le numéro de la position et numéro du tableau sur lequel figure la pièce;
- La référence et la dénomination;
- La quantité des pièces demandées;
- L'adresse exacte et la raison sociale de l'acheteur qui passe la commande, en indiquant l'adresse de livraison;
- Le moyen de transport désiré (dans le cas où ceci n'est pas précisé l'expéditeur se réserve le droit de choisir le transporteur).

DE - Die Beschreibungen, welche in der vorliegenden Veröffentlichung vorhanden sind, sind nicht verpflichtend. Die Firma behält sich das Recht vor jederzeit eventuelle Modifikationen an wesentlichen Baugruppen, Details und Zubehör-Teilen durchzuführen, wenn dies für vorteilhaft bewertet wird und zu einer Verbesserung führt oder aufgrund von konstruktiven oder kommerziellen Anforderungen. Die Vervielfältigung, auch wenn es sich nur um Text-Auszügen oder Abbildungen handelt, der vorliegenden Bedienungsanleitung ist entsprechend dem Gesetz untersagt. Die Firma behält sich das Recht vor technische Eigenschaften und Ausstattungen zu modifizieren. Die Abbildungen sind zum Verständnis und dienen als Bezug und sind nicht bindend in Bezug auf Design und Ausstattung.

EINLEITUNG:

Der vorliegende Katalog versteht sich als Führer für Ersatzteile und soll eine rasche Identifikation der Maschine in all ihren Ausführungen ermöglichen und daher ein

sofortiges Erkennen der Teile, aus denen sie besteht.

BESTELLVORSCHLAG:

Um ein Auffinden im Lager und den Versand der Ersatzteile zu erleichtern, werden die Kunden ersucht, sich an folgende Normen zu halten und immer folgendes anzugeben:

- Modell- und Gerätenummer;
- Positions- und Tafelnummer, wo sie dargestellt sind;
- Bestellnummer und Handelsbezeichnung;
- Menge der gewünschten Teile;
- Genaue Adresse und Firmennamen des Auftraggebers, gemeinsam der ev. Anschrift für die Zusendung der Ware;
- Die gewünschte Versandart (falls nicht angegeben, behält sich der Lieferant das Recht vor, die günstigste Art zu wählen)

ES - Las descripciones contenidas en la presente publicación no son empeñativas. La Empresa por lo tanto se reserva el derecho de aportar en cualquier momento, eventuales modificaciones a órganos, detalles, suministros de accesorios, que ella crea conveniente para una mejoría o por cualquier exigencia de carácter constructivo o comercial. La reproducción parcial de los textos y los diseños, contenidos en el presente catálogo, está prohibida por la ley. La Empresa se reserva el derecho a aportar modificaciones de carácter técnico e/o de dotación. Las imágenes son de pura referencia y no vinculantes en términos de diseño y dotación.

INTRODUCCIÓN:

Ese catálogo quiere servir cómo guía para pedir las piezas de repuesto y se ha realizado de manera de consentir una rápida identificación de la máquina en todas sus versiones y por consiguiente una rápida individuación de las piezas que la componen.

MODALIDADES DE LOS PEDIDOS:

Para la búsqueda en el almacén y el envío de las piezas de repuesto, se ruega encarecidamente a los Sres. Clientes de seguir las reglas siguientes y de especificar siempre:

- El modelo y el número de matrícula de la máquina;
- El número de posición y el número de la tabla donde son representadas;
- El código de pedido y la denominación;
- El número de piezas que se desean;
- Las señas exactas y la razón social del Comitente, indicando también las señas eventuales para la entrega de la mercancía;
- El medio de envío que se desea. (En caso de que ese dato no se haya especificado, la Empresa Constructora se reserva el derecho de utilizar a su elección el medio más adecuado.

AGGIORNAMENTI DALLA VERSIONE PRECEDENTE:

- = Documento valido dalla matricola.
- ← = Documento annullato dalla matricola.

UPDATES FROM THE PREVIOUS VERSION:

- = This document is valid since the serial number.
- ← = This document is valid till the serial number.

MISE À JOUR DE LA VERSION PRÉCÉDENTE:

- = Document valable à partir du numéro de série.
- ← = Document annulé par le numéro de série.

UPDATES FROM THE PREVIOUS VERSION:

- = This document is valid since the serial number.
- ← = This document is valid till the serial number.

ACTUALIZACIÓN DE LA VERSIÓN ANTERIOR:

- = Documento válido desde la matrícula n°.
- ← = Documento válido hasta la matrícula n°.

	PAG.	N. DOC.	VER.	SERIAL NUMBER

10055263-AA

00

CR-00 STRUTTURA PRODOTTO
 STRUCTURE OF THE MACHINE
 STRUCTURE DE LA MACHINE
 AUFBAU DER MASCHINE
 ESTRUCTURA DE LA MAQUINA

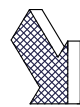
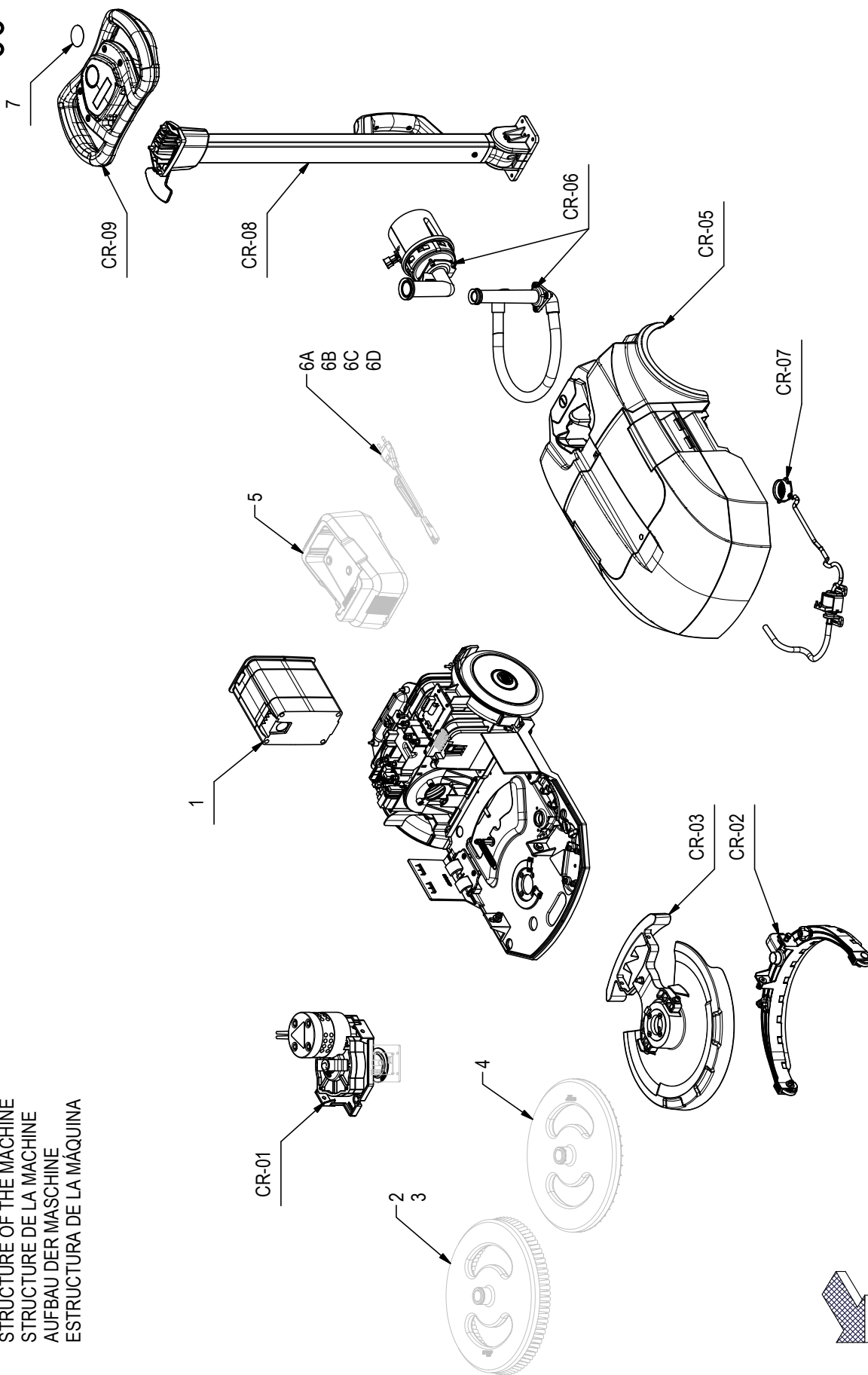

CR-00 STRUTTURA PRODOTTO

00

POS	CODICE	QTÀ	DESCRIZIONE	DENOMINATION	DESCRIPTION	BENENNUNG	DESCRIPCION
CR-01	224161	1	GRUPPO BASAMENTO	BRUSHES BASE ASSEMBLY	GRUPE PLATEAU DES BRUSSES	GRUPE BURSTENGESTELL	GRUPO BANCADA CEPILLOS
CR-02	224162	1	GRUPPO TERGIPAVIMENTO	SQUEEGEE ASSEMBLY	ENSEMBLE DE SUCEUR	SAUGFUSSGRUPPE	GRUPO LIMPIADORES DE SUELO
CR-03	224163	1	GRUPPO COMANDO TERGIPAVIMENTO	SQUEEGEE CONTROL ASSEMBLY	GRUPE COMMANDE DE SUCEUR	GRUPE	GRUPO MANDO LIMPIAPAVIMENTOS
CR-04	224159	1	GRUPPO TELAIO E CARROZZERIA	FRAME ASSEMBLY WITHOUT TRACTION	GRUPE DE CHASSIS SANS TRACTION	FAHRGESTELL GRUPPE OHNE ANTRIEB	GRUPO BASTIDOR SIN TRACCION
CR-05	224750	1	GRUPPO SERBATOI	TANK ASSEMBLY	GRUPE DE RESERVOIRE	GRUPE TANKE	GRUPO TANQUE
CR-06	224165	1	GRUPPO ASPIRAZIONE	SUCTION MOTOR ASSEMBLY	GRUPE MOTEUR D'ASPIRATION	SAUGMOTORGRUPE	GRUPO MOTOR SUCCION
CR-07	224166	1	GRUPPO IDRICO	WATER UNIT	GRUPE HYDRIQUE	WASSERGRUPPE	GRUPO AGUA
CR-08	224167	1	GRUPPO MANUBRIO	GROUP STEERING CONTROL	COMMANDE DE DIRECTION DU GROUPE	GROUP LENKKONTROLLE	GRUPO DE MANDO DE DIRECCION
CR-09	224168	1	GRUPPO VOLANTE	STEERING GROUP	GRUPE DE PILOTAGE	LENKUNGS	GRUPO DIRECTIVO
1	440141	1	BATTERIA LI-ION 36,5V 5400 mAh	BATTERY	BATTERIE	BATTERIE	BATERIAS
2	439929	1	SPAZZOLA PPL 0.3	BRUSH	BROSSE	BÜRSTE	CEPILLO
3	441041	1	SPAZZOLA PPL 0.2	BRUSH	BROSSE	BÜRSTE	CEPILLO
4	439930	1	DISCO TRASCINATORE	PAD HOLDER	DISQUE ENTRAÎNEUR	TREIBTELLERS	DISCO DE ARRASTRE
5	440807	1	BASE CARICABATTERIA	BODY CHARGER	CORPS CHARGEUR	BODY CHARGER	CUERPO CARGADOR
6A	439666	1	CAVO ALIMENT. BASE CARICABATTERIA EU	BODY POWER CABLE CHARGER (EU)	CORPS CORDON D'ALIMENTATION CHARGEUR (EU)	BODY POWER CABLE CHARGER (EU)	CUERPO DE ALIMENTACION CABLE CARGADOR (EU)
6B	441114	1	CAVO ALIMENT. BASE CARICABATTERIA UK	BODY POWER CABLE CHARGER (UK)	CORPS CORDON D'ALIMENTATION CHARGEUR (UK)	BODY POWER CABLE CHARGER (UK)	CUERPO DE ALIMENTACION CABLE CARGADOR (UK)
6C	441037	1	CAVO ALIMENT. BASE CARICABATTERIA JP - US	BODY POWER CABLE CHARGER (JP - US)	CORPS CORDON D'ALIMENTATION CHARGEUR (JP - US)	BODY POWER CABLE CHARGER (JP - US)	CUERPO DE ALIMENTACION CABLE CARGADOR (JP - US)
6D	441036	1	CAVO ALIMENT. BASE CARICABATTERIA AU - CN	BODY POWER CABLE CHARGER (AU - CN)	CORPS CORDON D'ALIMENTATION CHARGEUR (AU - CN)	BODY POWER CABLE CHARGER (AU - CN)	CUERPO DE ALIMENTACION CABLE CARGADOR (AU - CN)
7	438616	1	ETICHETTA CIRCOLARE COMAC D=33	DECAL	ETIQUETTE	SCHILD	ETIQUETA

10049477-AA

01

CR-01 GRUPPO BASAMENTO
 BRUSHES BASE ASSEMBLY
 GROUPE PLATEAU DES BROSSES
 GRUPPE BÜRSTENGESTELL
 GRUPO BANCADA CEPILLOS

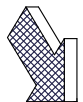
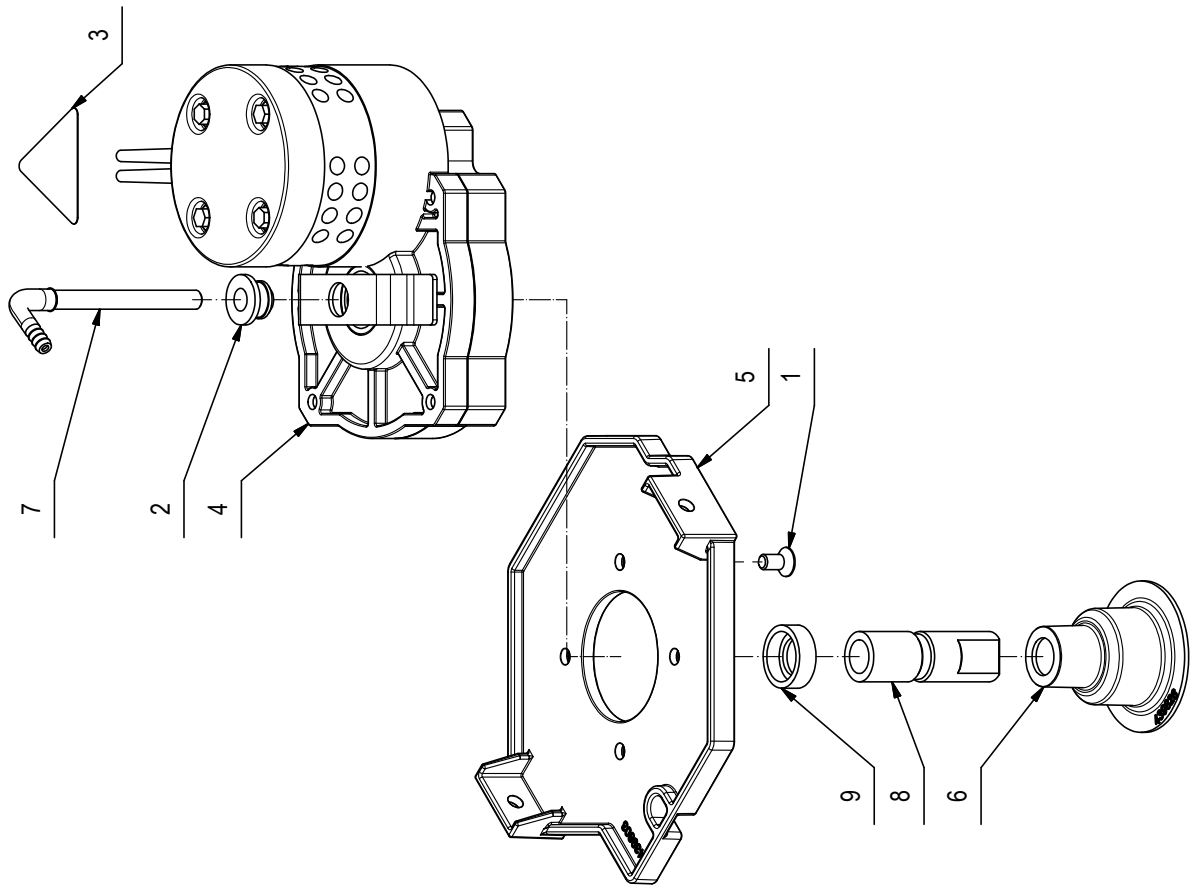

10049477-AA

CR-01 GRUPPO BASAMENTO

01

POS	CODICE	QTA	DESCRIZIONE	DENOMINATION	DESCRIPTION	BENENNUNG	DESCRIPCION
1	408965	4	VITE M6X12 TPSEI UNI6933 ZINC	SCREW	VIS	SCHRAUBE	TORNILLO
2	428561	1	GUARNIZIONE D=20 d=8 L=12,5 TIPO PWS8	GASKET	JOINT	DICHTUNG	JUNTA
3	435453	1	ETICHETTA "ATTENZIONE SUPERFICIE CALDA"	DECAL	ETIQUETTE	SCHILD	ETIQUETA
4	439433	1	MOTORID. 36V 90W 150RPM ALBERO FIL. SX	GEARED MOTOR	MOTO-REDUCTEUR	GETRIEBEMOTOR	MOTORREDUCTOR
5	439803	1	SUPPORTO MOTORE SPAZZOLA	MOTOR SUPPORT	SUPPORT DE MOTEUR	MOTORHALTERUNG	SOPORTE DE MOTOR
6	439826	1	FLANGIA SPAZZOLA	FLANGE	FLASQUE	FLANSCH	BRIDA
7	439864	1	TUBO ACQUA CENTRALE	PIPE	TUBE	ROHR	TUBO
8	439970	1	ALBERO MOTORIDUTTORE INFERIORE	SHAFT	ARBRE	WELLE	EJE
9	441515	1	DISTANZIALE D=25 d=15-20 S=8 AISI 303	SPACER	ENTRETOISE	DISTANZHÜLSE	DISTANCIADOR

10049478-AA

02

CR-02 GRUPPO TERGIPAVIMENTO

SQUEEGEE ASSEMBLY
 ENSEMBLE DE SUCEUR
 SAUGFUSSGRUPPE
 GRUPO LIMPIADOR DE SUELO

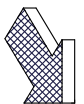
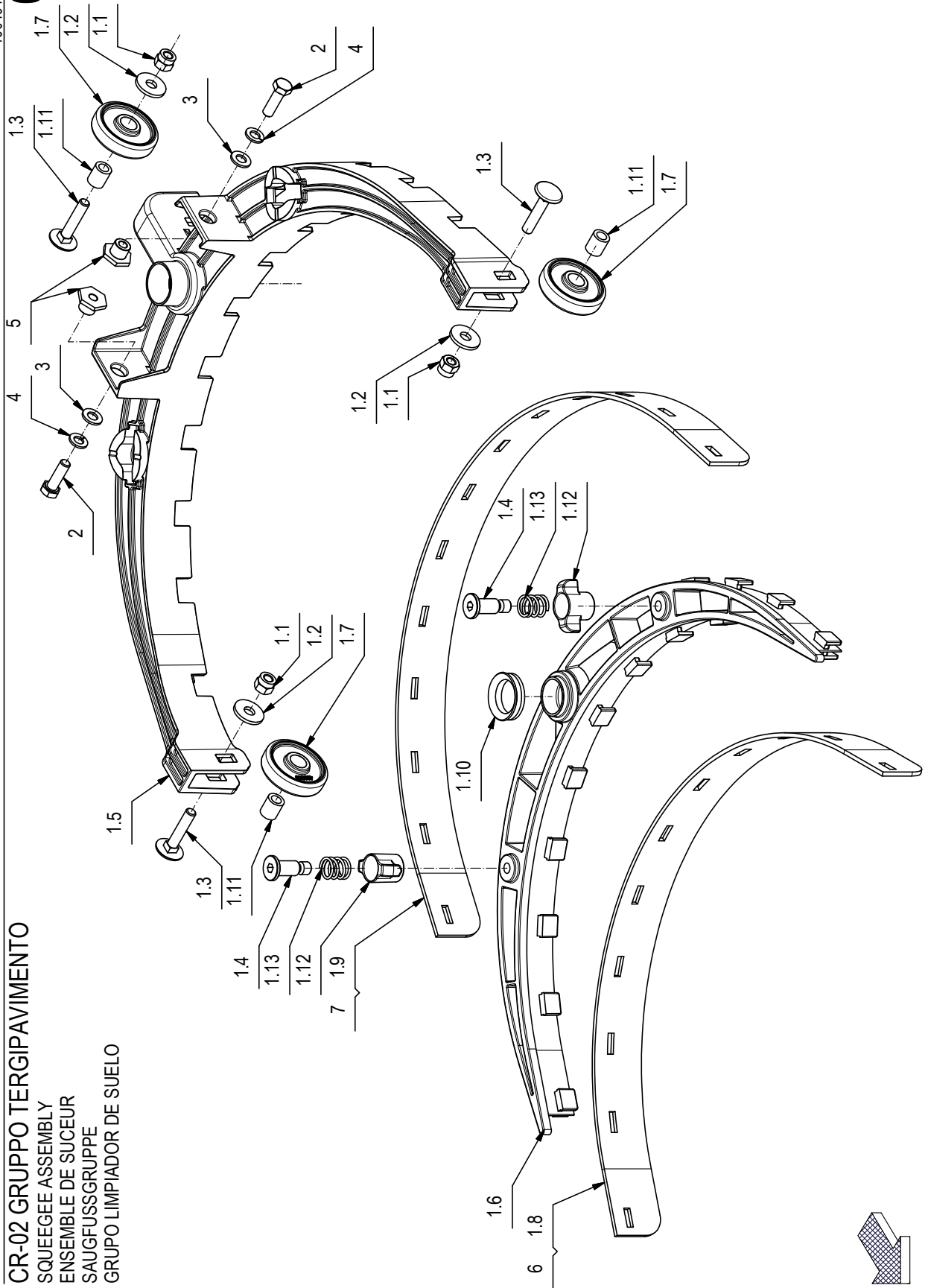

CR-02 GRUPPO TERGIPAVIMENTO

02

POS	CODICE	QTA	DESCRIZIONE	DENOMINATION	DESCRIPTION	BENENNING	DESCRIPCION
1	224174	1	PREM. TERGIPAVIMENTO	SQUEEGEE ASSEMBLY	ENSEMBLE DE SUCEUR	SAUGFUSSGRUPPE	GRUPO LIMPIADORES DE SUELO
1.1	409081	3	DADO M5x7 AUTOBL. UNI 7473 A2	LOCK NUT	ECROU AUTOBLOCANT	SICHERUNGSMUTTER	TUERCA AUTOBLOCANTE
1.2	409152	3	ROSETTA 5x15x1.5 UNI 6593 A2	WASHER	RONDELLE	SCHEIBE	ARANDELA
1.3	421930	3	VITE M5x25 TTQST UNI 5732 INOX	SCREW	VIS	SCHRAUBE	TORNILLO
1.4	430903	2	PERNO MANOPOLINA D=11,8 d=7 M=6 H=22	PIN	AXE	BOLZEN	PERNO
1.5	439792	1	CORPO TERGIPAVIMENTO SUPERIORE	SQUEEGEE BODY	CORPS DE SUCEUR	SAUGFUSSKÖRPER	CUERPO LIMPIAPAVIMENTOS
1.6	439797	1	CORPO TERGIPAVIMENTO INFERIORE	SQUEEGEE BODY	CORPS DE SUCEUR	SAUGFUSSKÖRPER	CUERPO LIMPIAPAVIMENTOS
1.7	439808	3	RUOTA TERGIPAVIMENTO	POLYURETHANE WHEEL	ROUE POLYURETHANE	POLYURETHANRAD	RUEDA DE POLIURETANO
1.8	439839	1	GOMMA TERGI ANT. LINATEX	FRONT RUBBER	BAVETTE AVANT	VORDERER SAUGGUMMI	GOMA DELANTERA
1.9	439841	1	GOMMA TERGI POST. LINATEX	REAR RUBBER	BAVETTE ARRIERE	HINTERER SAUGGUMMI	GOMA TRASERA
1.10	440025	1	GUARNIZIONE V-RING TIPO VA0018 H=5,5 NBR	GASKET	JOINT	DICHTUNG	JUNTA
1.11	440860	3	BOCCOLA D=8,2 d=5,1 S=9,5	BUSHING	BAGUE	BUCHSE	CASQUILLO
1.12	441481	2	MANOPOLINA FISSAGGIO TERGI XS/FIMOP	WING NUT	PAPILLON	FLÜGELSCHRAUBE	POMO
1.13	441482	2	MOLLA COMP. De=10,5 Df=1,2 L=11,3 It=4	SPRING	RESSORT	FEDER	RESORTE
2	407646	2	VITE M5x16 TE UNI 5739 A2	SCREW	VIS	SCHRAUBE	TORNILLO
3	409149	2	ROSETTA 5x10x1 UNI 6592 A2	WASHER	RONDELLE	UNTERLEGSCHHEIBE	ARANDELA
4	409155	2	ROSETTA M5 UNI 1751 INOX GROWER	WASHER	RONDELLE	UNTERLEGSCHHEIBE	ARANDELA
5	439927	2	BOCCOLA TERGI - PARTE TERGIPAVIMENTO	BUSHING	BAGUE	BUCHSE	CASQUILLO
7	440243	1	GOMMA TERGIPAVIMENTO POST. 40Sh	REAR RUBBER	BAVETTE ARRIERE	HINTERER SAUGGUMMI	GOMA TRASERA
6	440217	1	GOMMA TERGIPAVIMENTO ANT. 40Sh	FRONT RUBBER	BAVETTE AVANT	VORDERER SAUGGUMMI	GOMA DELANTERA

10049480-AA

03

CR-03 GRUPPO COMANDO TERGIPAVIMENTO

SQUEEGEE CONTROL ASSEMBLY
 GROUPE COMMANDE DE SUCEUR
 GRUPPE SAUGFUSSBETÄTIGUNG
 GRUPO MANDO LIMPIAPAVIMENTOS

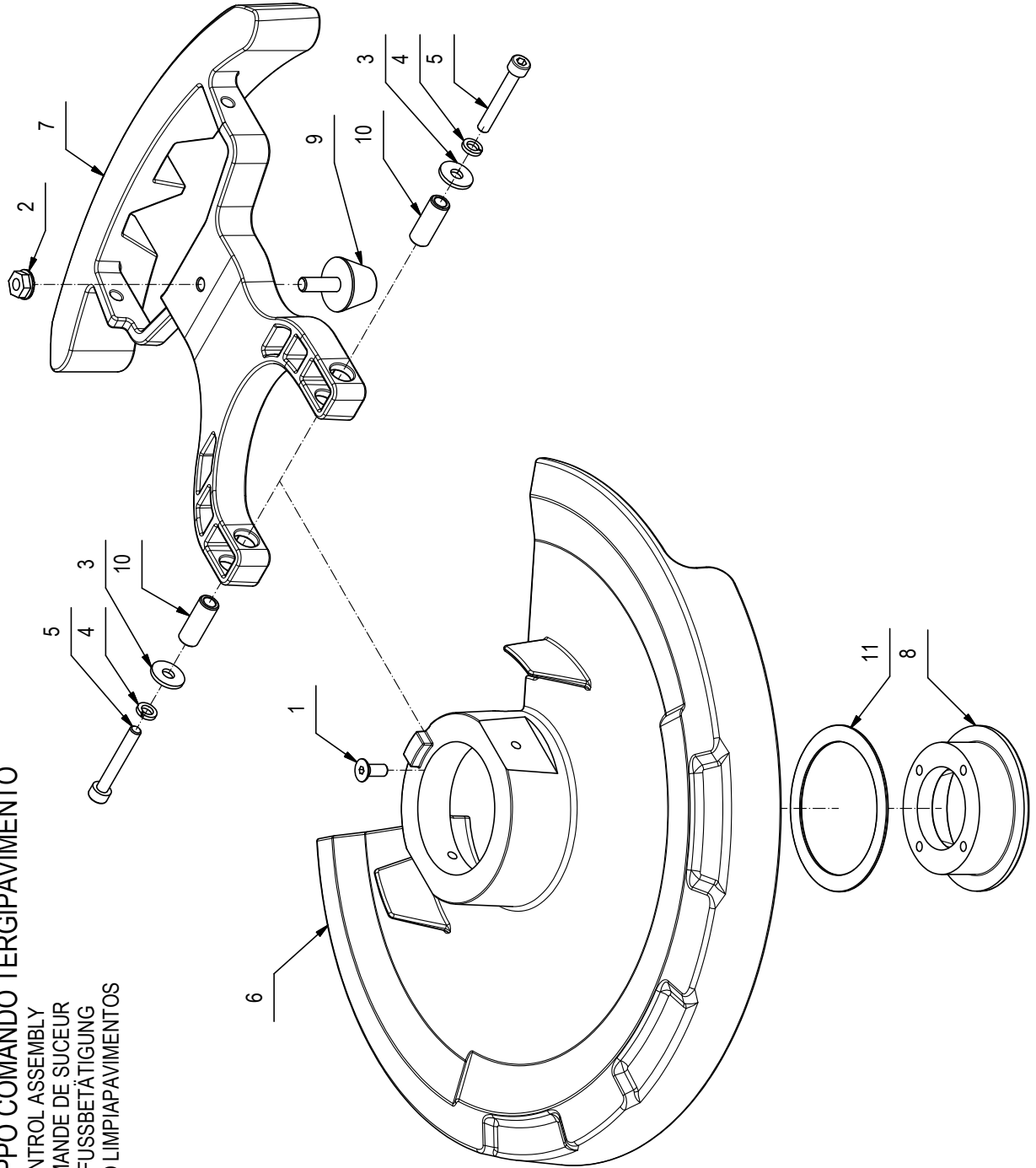

10049480-AA

CR-03 GRUPPO COMANDO TERGIPAVIMENTO

03

POS	CODICE	QTA	DESCRIZIONE	DENOMINATION	DESCRIPTION	BENENNUNG	DESCRIPCION
1	408963	4	VITE M5x12 TPSEI UNI5933 A2	SCREW	VIS	SCHRAUBE	TORNILLO
2	409125	1	DADO M6 SERPRESS	NUT	ECROU	MUTTER	TUERCA
3	409151	2	ROSETTA 5x15x1.5 UNI 6593 ZINC	WASHER	RONDELLE	UNTERLAGSCHEIBE	ARANDELA
4	409154	2	ROSETTA GROWER 5x1,6 ZINC	WASHER	RONDELLE	UNTERLAGSCHEIBE	ARANDELA
5	415759	2	VITE M5x35 TCEI UNI 5931	SCREW	VIS	SCHRAUBE	TORNILLO
6	439805	1	CARTER BASAMENTO	SUPPORT	SUPPORT	HALTERUNG	SOPORTE
7	439806	1	ATTACCO TERGI GENIE XS	COUPLING	ATTAQUE	KUPPLUNG	ACOPLAMIENTO
8	439807	1	SUPPORTO RALLA	SUPPORT	SUPPORT	HALTERUNG	SOPORTE
9	439967	1	PIEDINO ANTIVIBR 174/140 23X16 SP.18 6MA	CAP	BOUCHON	STOPFEN	TAPON
10	439968	2	BOCCOLA D=8,8 d=5,5 S=22,5 OT	BUSHING	BAGUE	BUCHSE	CASQUILLO
11	439969	1	BOCCOLA STRICIAM. IGLIDUR JTM-5670-010	BUSHING	BAGUE	BUCHSE	CASQUILLO

10049481-AA

04

CR-04 GR. TELAIO E CARROZZERIA

BODYWORK ASSEMBLY
 GROUPE DE CARROSSERIE
 GRUPPE FAHRGESTELL
 GRUPO CARROGERIA

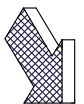
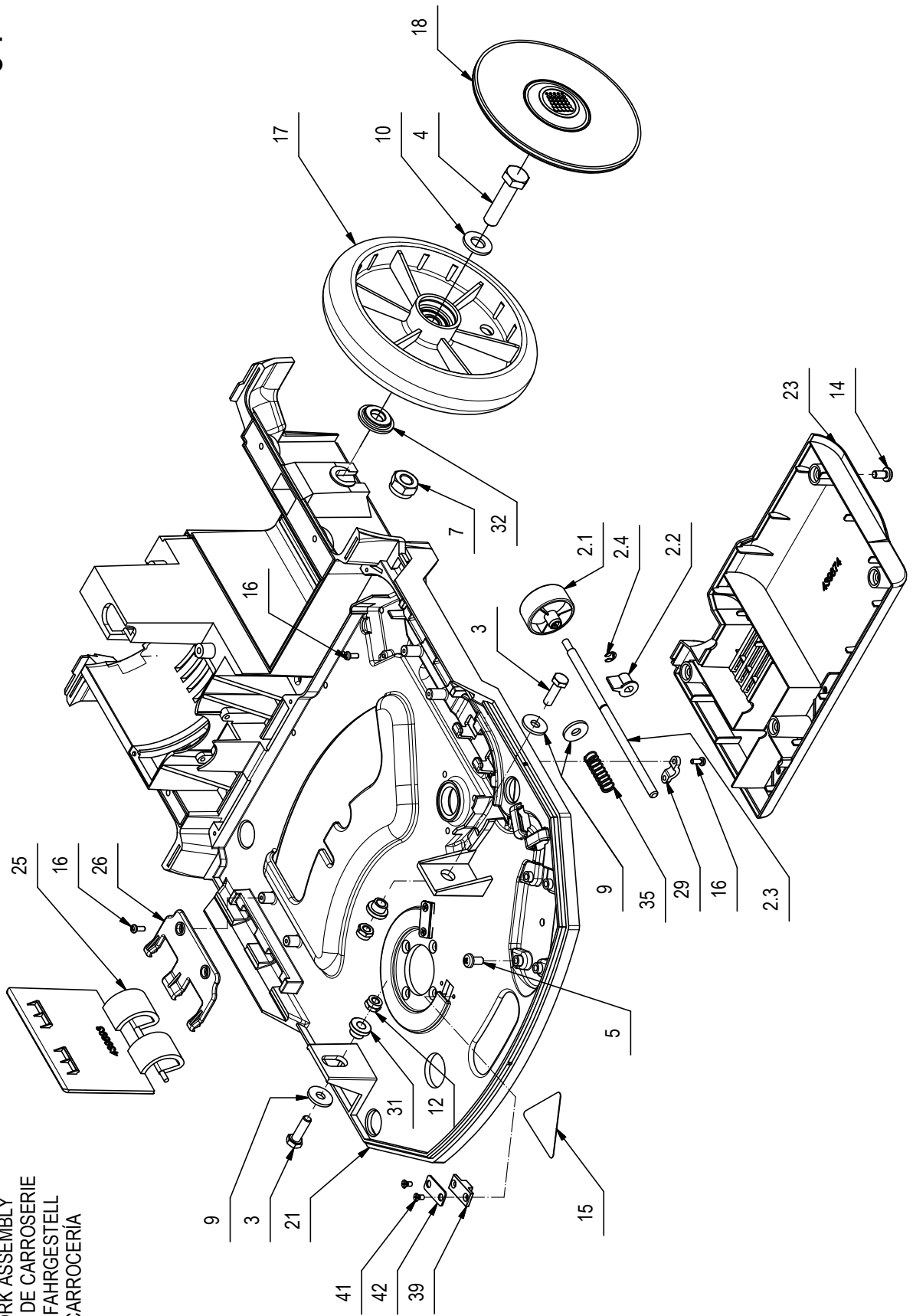

CR-04 GR. TELAIO E CARROZZERIA

04

POS	CODICE	QTÀ	DESCRIZIONE	DENOMINATION	DESCRIPTION	BENENNUNG	DESCRIPCION
1	206813	1	PROLUNGA CAVO	EXTENSION TUBE	TUBE D'EXTENSION	VERLANGERUNGSSTUCK	TUBO DE EXTENSION
2	224880	1	PREM. LEVA SOLL. TERGIPAVIMENTO GENIE XS	PRE-ASSEMBLY BODY LIFT LEVER SQUEEGEE	PRE-ASSEMBLEE CORPS LEVER SQUEEGEE	VORMONTAGE BODY LIFT HEBEL SQUEEGEE	PRE-ASSEMBLEA PALANCA DE ELEVAZIONE DEL CU
2.1	439908	1	MANOPOLA SOLLEVAMENTO RAL 7016	KNOB	POIGNEE	HANDGRIFF	EMPUÑADURA
2.2	439910	1	FERMO LEVA SOLLEVAMENTO	STOP	ARRET	STOPBELEG	PLAQUETA DE SUJECION
2.3	439915	1	LEVA SOLLEVAMENTO TERGIPAVIMENTO	ROD	TIGE	STANGE	VARILLA
2.4	439974	1	ANELLO ELASTICO UNI 7434 - 4	SEEGER RING	SERRE CLIPS	SEEGERRING	ANILLO SEEGER
3	407667	2	VITE M6x20 TE UNI 5739 A2	SCREW	VIS	SCHRAUBE	TORNILLO
4	408715	2	VITE M10x40 TE UNI 5739 (8.8)	SCREW	VIS	SCHRAUBE	TORNILLO
5	408848	4	VITE M5X10 TCTC UNI 7687 A2	SCREW	VIS	SCHRAUBE	TORNILLO
6	408853	1	VITE M5X16 TCTC UNI 7045 A2	SCREW	VIS	SCHRAUBE	TORNILLO
7	409090	2	DADO M10x10 AUTOBL. UNI 7474 ZINC	LOCK NUT	ECROU AUTOFREINES	SICHERUNGSMUTTER	TUERCA AUTOBLOCANTE
8	409152	2	ROSETTA 5x15x1.5 UNI 6593 A2	WASHER	RONDELLE	SCHEIBE	ARANDELA
9	409161	3	ROSETTA 6.6x18x2 UNI 6593 A2	WASHER	RONDELLE	SCHEIBE	ARANDELA
10	409191	2	ROSETTA 10X21X2 UNI 6592 ZINC	WASHER	RONDELLE	UNTERLAGSCHEIBE	ARANDELA
11	415763	4	VITE M4X10 TCTC UNI 7687 INOX A2	SCREW	VIS	SCHRAUBE	TORNILLO
12	415901	2	DADO M6 AUTOBL. UNI 7474 INOX	NUT	ECROU	MUTTER	TUERCA
13	416781	7	DADO M5X5 AUTOBL. UNI 7473 ZINC	LOCK NUT	ECROU AUTOFREINES	SICHERUNGSMUTTER	TUERCA AUTOBLOCANTE
14	418311	10	VITE M5x10 TCTC UNI 7687 (4.8) ZINC.	SCREW	VIS	SCHRAUBE	TORNILLO
15	435453	1	ETICHETTA "ATTENZIONE SUPERFICIE CALDA"	DECAL	ETIQUETTE	SCHILD	ETIQUETA
16	438688	11	VITE M3X8 TCTC UNI 7687 INOX A2	SCREW	VIS	SCHRAUBE	TORNILLO
17	439343	2	RUOTA D=160 S=30	WHEEL	ROUE	RAD	RUEDA
18	439345	2	COPERCHIO RUOTA D=126 RAL 7016	COVER	COUVERCLE	DECKEL	TAPA
19	439524	1	INTERRUTTORE UNIPOLARE SB-50A1L11Q	SWITCH	INTERRUPTEUR	SCHALTER	INTERRUPTOR
20	439802	1	SCHEDA COMANDI CFSS000-230414	CHECK CARD CONTROLS	PLAQUE CONTR. COMMANDES	KONTROLLEL. SCHALTUNGEN	FICHA CONTROL MANDOS
21	439870	1	TELAIO BASE GENIE XS	FRAME	CHASSIS	RAHMEN	BASTIDOR
22	439871	1	TELAIO SUPERIORE COMPLETO	UPPER FRAME	CHASSIS SUPERIEUR	OBERES GESTELL	BASTIDOR SUPERIOR
23	439874	1	COPERTURA INFERIORE TELAIO	COVER	COUVERCLE	ABDECKUNG	CARTER
24	439882	1	GRIGLIA MOTORE	COVER	COUVERCLE	DECKEL	TAPA
25	439893	2	LEVA BLOCCO SERBATOI	COVER HINGE	CHARNIERE COUVERCLE	DECKELSCHARNIER	BISAGRA TAPA
26	439894	2	CAVALLOTTO CERNIERA LEVA SERBATOI	HINGE	CHARNIERE	SCHARNIER	BISAGRA
27	439903	1	SUPPORTO TASTO	SUPPORT	SUPPORT	HALTERUNG	SOPORTE
28	439904	1	BLOCCETTO CONTATTI BATTERIA	BLOCK	PETIT BLOC	ARRETIERUNG	BLOQUE
29	439907	1	FERMO PERNO MANOPOLA	STOP	ARRET	STOPBELEG	PLAQUETA DE SUJECION

10049481-AA

04

CR-04 GR. TELAIO E CARROZZERIA

BODYWORK ASSEMBLY
 GROUPE DE CARROSERIE
 GRUPPE FAHRGESTELL
 GRUPO CARROCERIA

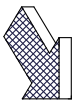
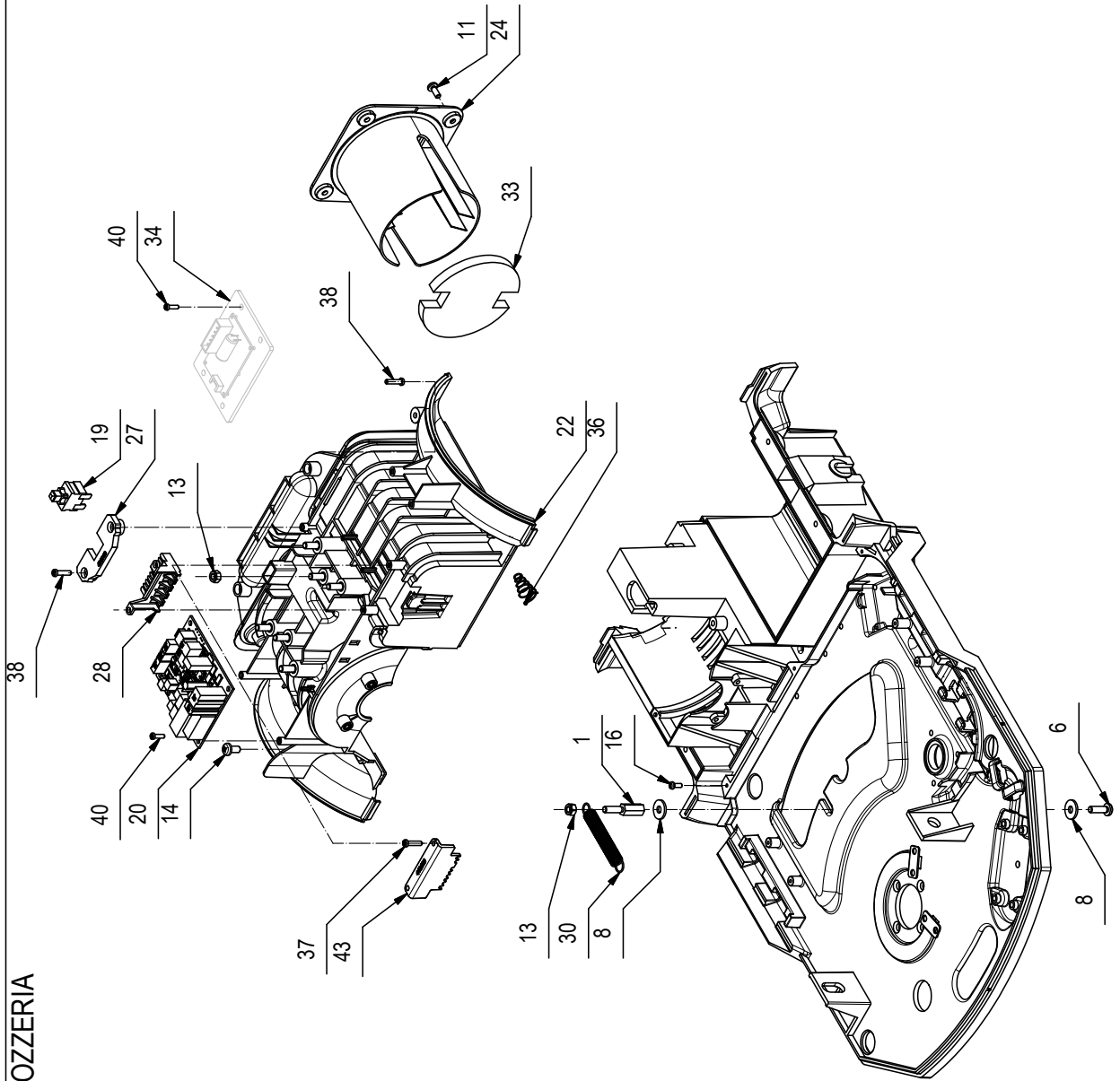

10049481-AA

04

CR-04 GR. TELAIO E CARROZZERIA

POS	CODICE	QTÀ	DESCRIZIONE	DENOMINATION	DESCRIPTION	BENENNUNG	DESCRIPCION
30	439924	1	MOLLA TRAZ. 10x1x54	SPRING	RESSORT	FEDER	RESORTE
31	439931	2	BOCCOLA D=15-10 d=6,5 S=8,3 OT58	BUSHING	BAGUE	BUCHSE	CASQUILLO
32	439951	2	DISTANZIALE RUOTA	BUSHING	BAGUE	BUCHSE	CASQUILLO
33	440136	1	FILTRO ANTIPOLVERE	FILTER	FILTRE	FILTER	FILTRO
34	440247	1	SCHEDA CONTROLLO MOTORE BRUSHLESS				
35	440664	1	MOLLA COMPR. 9,5x0,8x30 A2	SPRING	RESSORT	FEDER	RESORTE
36	440855	1	MOLLA BATTERIA	SPRING	RESSORT	FEDER	RESORTE
37	440886	2	VITE AUTOF. D.3.5 x 14 UNI 9707-Pz-TZ A2	SCREW	VIS	SCHRAUBE	TORNILLO
38	440893	6	VITE AUTOF. D.3.5 x 14 UNI 9707-Pz-TZ ZN	SCREW	VIS	SCHRAUBE	TORNILLO
39	440998	2	FINECORSO CARTER BASAMENTO	STOP	FIN DE COURSE	ENDANSCHLAG	FIN DE CARRERA
40	441027	4	VITE AUTOF. D.3 x 10 UNI 9707-Pz-TZ A2	SCREW	VIS	SCHRAUBE	TORNILLO
41	441077	4	VITE M3X6 TPSTC UNI 7688 INOX	SCREW	VIS	SCHRAUBE	TORNILLO
42	441470	2	PIASTRINA FISSAGGIO FINECORSO	SUPPORT	ATTAQUE	HALTERUNG	SOPORTE FIJADOR
43	441620	1	BLOCCO CONTATTI BATTERIA	HOLDFAST	ETAU	KLEMME	MORDAZA

10055155-AA

05

CR-05 GRUPPO SERBATOI

TANK GROUP
 GROUPE DE RÉSERVOIR
 TANK GROUP
 GRUPO DE TANQUE

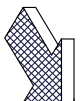
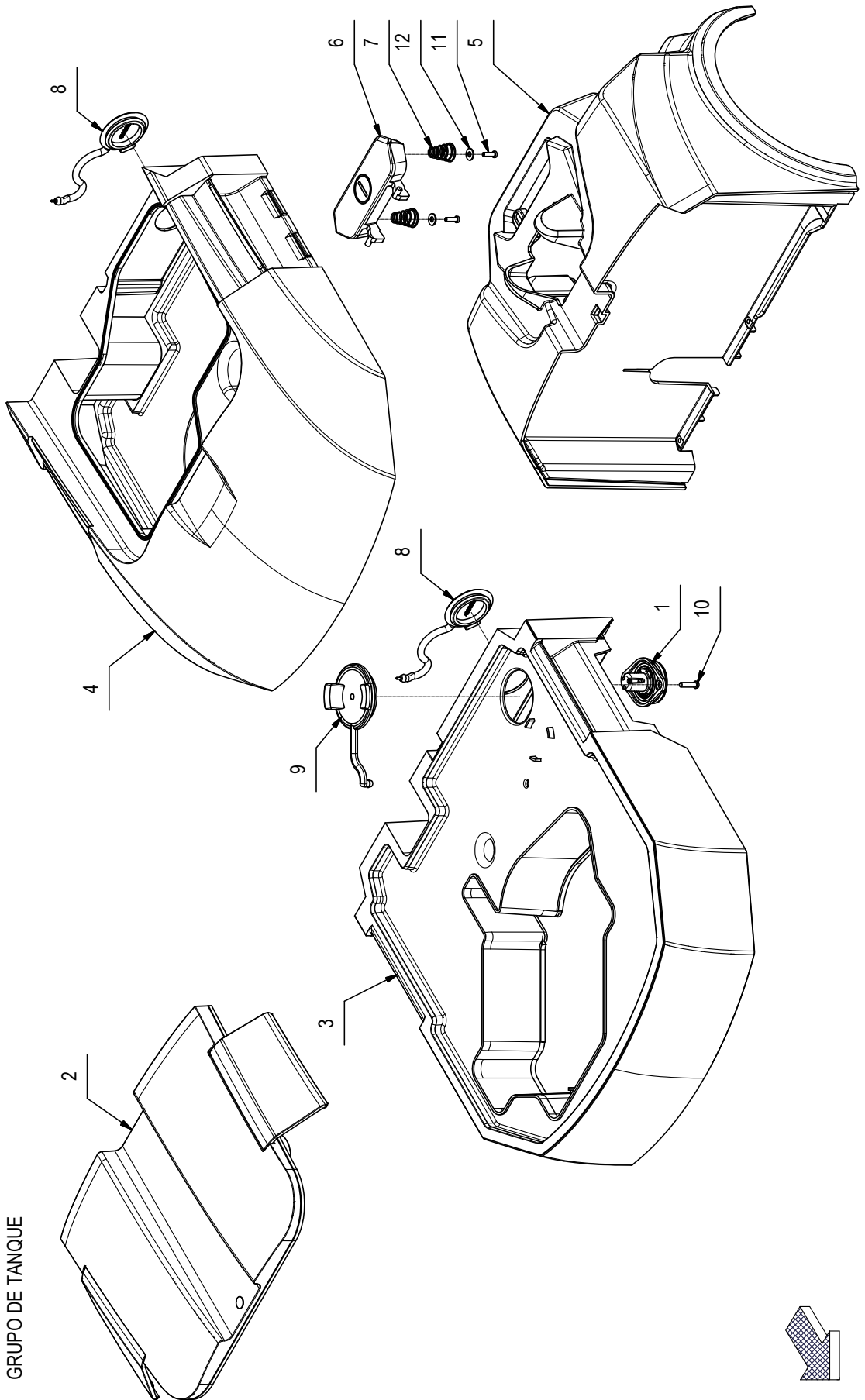

10055155-AA

05

CR-05 GRUPPO SERBATOI

POS	CODICE	QTÀ	DESCRIZIONE	DENOMINATION	DESCRIPTION	BENENNUNG	DESCRIPCION
1	224175	1	ASSIEME VALVOLA ACQUA	VALVE	SOUPAPE	VENTIL	VALVULA
2	224751	1	PREM. COPERCHIO SERBATOIO	COVER	COUVERCLE	DECKEL	TAPA
3	441486	1	SERBATOIO SOLUZIONE	SOLUTION TANK	RESERVOIR EAU PROPRE	FRISCHWASSERTANK	TANQUE SOLUTION
4	441485	1	SERBATOIO RECUPERO	RECOVERY TANK	RESERVOIR EAU SALE	SCHMUTZWASSERTANK	TANQUE AGUA SUCIA
5	441487	1	CARTER COPERTURA SUPERIORE	COVER	COUVERCLE	ABDECKUNG	CARTER
6	439902	1	TASTO ON/OFF	PUSH BUTTON	BOUTON POUSSOIR	DRUCKKNOPF	PULSADOR
7	440887	2	MOLLA D=14,4 d=6,2 H=19 FILO=0,8 A2	SPRING	RESSORT	FEDER	RESORTE
8	439892	2	TAPPO Ø25mm SCARICO SERBATOIO	CAP	CAPUCHON	KAPPE	TAPON
9	441073	1	TAPPO SERB. GENIE XS CON VALVOLA	CAP	CAPUCHON	KAPPE	TAPON
10	440886	2	VITE AUTOF. D.3.5 x 14 UNI 9707-Pz-TZ A2	SCREW	VIS	SCHRAUBE	TORNILLO
11	441027	2	VITE AUTOF. D.3 x 10 UNI 9707-Pz-TZ A2	SCREW	VIS	SCHRAUBE	TORNILLO
12	409143	2	ROSETTA 4X9X0,8 UNI 6592 A2	WASHER	RONDELLE	UNTERLEGSCHLEIBE	ARANDELA

10049494-AA

06

CR-06 GRUPPO ASPIRAZIONE
 SUCTION MOTOR ASSEMBLY
 GROUPE MOTEUR D'ASPIRATION
 SAUGMOTORGRUPE
 GRUPO MOTOR SUCCION

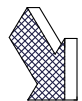
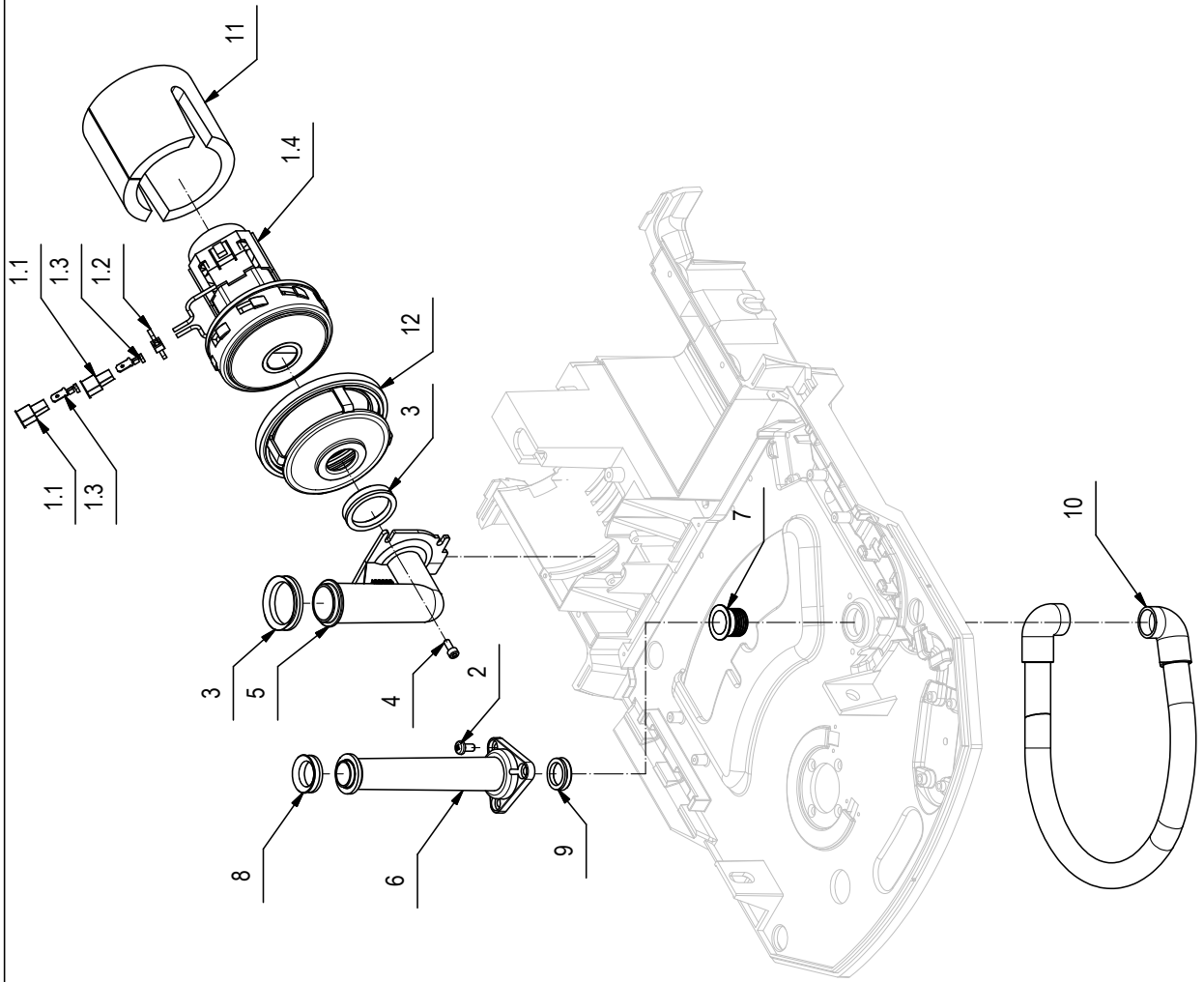

CR-06 GRUPPO ASPIRAZIONE

06

POS	CODICE	QTÀ	DESCRIZIONE	DENOMINATION	DESCRIPTION	BENENNUNG	DESCRIPCION
1	224555	1	PREM. MOTORE ASPIRAZIONE	SUCTION MOTOR	MOTEUR D'ASPIRATION	SAUGMOTOR	MOTOR DE ASPIRACION
1.1	409951	2	COPRIFASTON MASCHIO 6,3	FASTON COVER	COUVERCLE DE FASTON	DECKEL FASTON	CUBREFASTON
1.2	410274	1	FASCETTA PLASTICA 2,5x98	CLAMP	COLLIER	BRIDE	ABRAZADERA
1.3	416087	2	FASTON MASCHIO NUDO D.6,3	FASTON	FASTON	FASTON	FASTON
1.4	439574	1	MOTORE ASPIRAZIONE 36V 150W	SUCTION MOTOR	MOTEUR D'ASPIRATION	SAUGMOTOR	MOTOR DE ASPIRACION
2	408848	3	VITE M5X10 TCTC UNI 7687 A2	SCREW	VIS	SCHRAUBE	TORNILLO
3	421109	2	GUARNIZIONE V-RING VA30 H=7,5 NBR	V-RING	JOINT	V-RING	JUNTA ANULAR
4	423460	4	VITE M4X10 TCEI UNI 5931 A2	SCREW	VIS	SCHRAUBE	TORNILLO
5	439883	1	CONDOTTO ASPIRAZIONE MOTORE	SUCTION HOSE	FLEXIBLE ASPIRATION	SAUGSCHLAUCH	TUBO DE ASPIRACION
6	439884	1	CONDOTTO ASPIRAZIONE TERGI	FLANGE	FLASQUE	FLANSCH	BRIDA
7	439917	1	BOCCOLA FLANGIATA PER ROTAZ TUBO TERGI	BUSHING	BAGUE	BUCHSE	CASQUILLO
8	439977	1	GUARNIZIONE V-RING TIPO VA0020 H=7,5 NBR	O-RING	JOINT	O-RING	JUNTA ANULAR
9	440025	1	GUARNIZIONE V-RING TIPO VA0018 H=5,5 NBR	GASKET	JOINT	DICHTUNG	JUNTA
10	440026	1	TUBO SPIR. CON MANICOTTI D=22 ø=18 L=460	SUCTION HOSE	FLEXIBLE ASPIRATION	SAUGSCHLAUCH	TUBO DE ASPIRACION
11	440027	1	FONOASSORBENTE D=85 ø=65 H=70 S=10	DEADENING	ISOLANT PHONIQUE	SCHALLDICHTUNG	FONOASSORBENTE
12	440833	1	CUFFIA MOTORE ASPIRAZIONE	GASKET	JOINT	DICHTUNG	JUNTA

1004949T-AA

07

CR-07 GRUPPO IDRICO

WATER UNIT
 GROUPE HYDRIQUE
 WASSERGRUPPE
 GRUPO AGUA

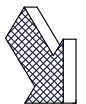
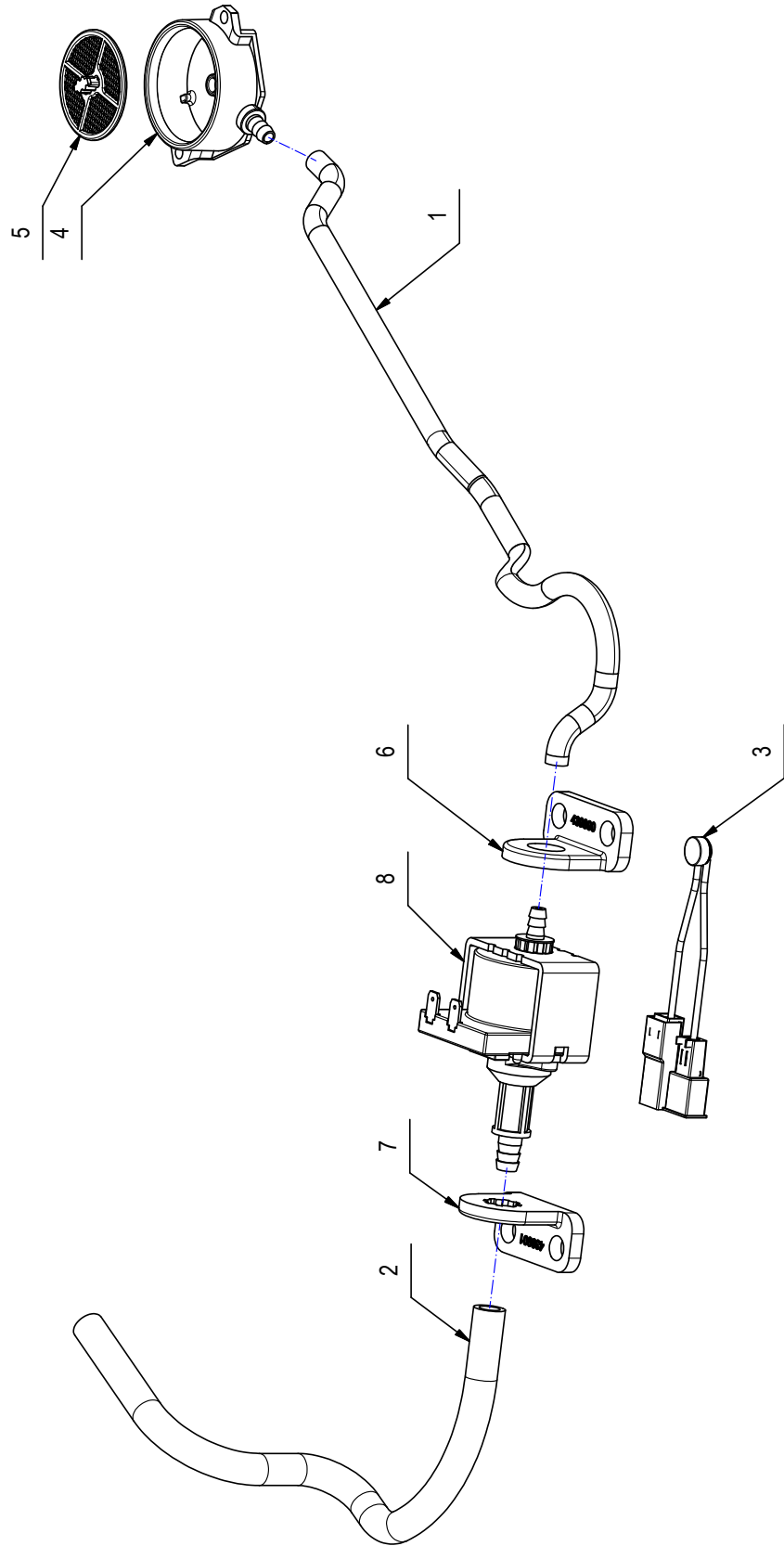

10049497-AA

CR-07 GRUPPO IDRICO

07

POS	CODICE	QTÀ	DESCRIZIONE	DENOMINATION	DESCRIPTION	BENENNUNG	DESCRIPCION
1	224270	1	TUBO SILICONE D=7 d=4 L=260	PIPE	TUBE	ROHR	TUBO
2	224271	1	TUBO SILICONE D=8 d=5 L=230	PIPE	TUBE	ROHR	TUBO
3	225370	1	SONDA TERMICA 90°C + FASTON 4,8 x 0,8	THERMAL PROBE	CAPTEUR THERMIQUE	TEMPERATURSENSOR	SENSOR TÉRMICO
4	439887	1	SEDE VALVOLA ACQUA PULITA	VALVE	SOUPAPE	VENTIL	VALVULA
5	439888	1	FILTRO ACQUA PULITA 18 MESH	FILTER	FILTRE	FILTER	FILTRO
6	439900	1	SUPPORTO ANTIVIBRANTE POMPA	SUPPORT	SUPPORT	HALTERUNG	SOPORTE
7	439901	1	SUPPORTO ANTIVIBRANTE POMPA - BLOCCO	SUPPORT	SUPPORT	HALTERUNG	SOPORTE
8	440028	1	ELETTROPOMPA ULKA NME1	PUMP ASSEMBLY	POMPE COMPLETE	PUMPE KOMPLETT	BOMBA COMPLETA

10049499-AA

08

CR-08 GRUPPO MANUBRIO
 STEERING COLUMN GROUP
 GROUPE DE PILOTAGE
 STEUERGRUPPE
 GRUPO DIRECTIVO

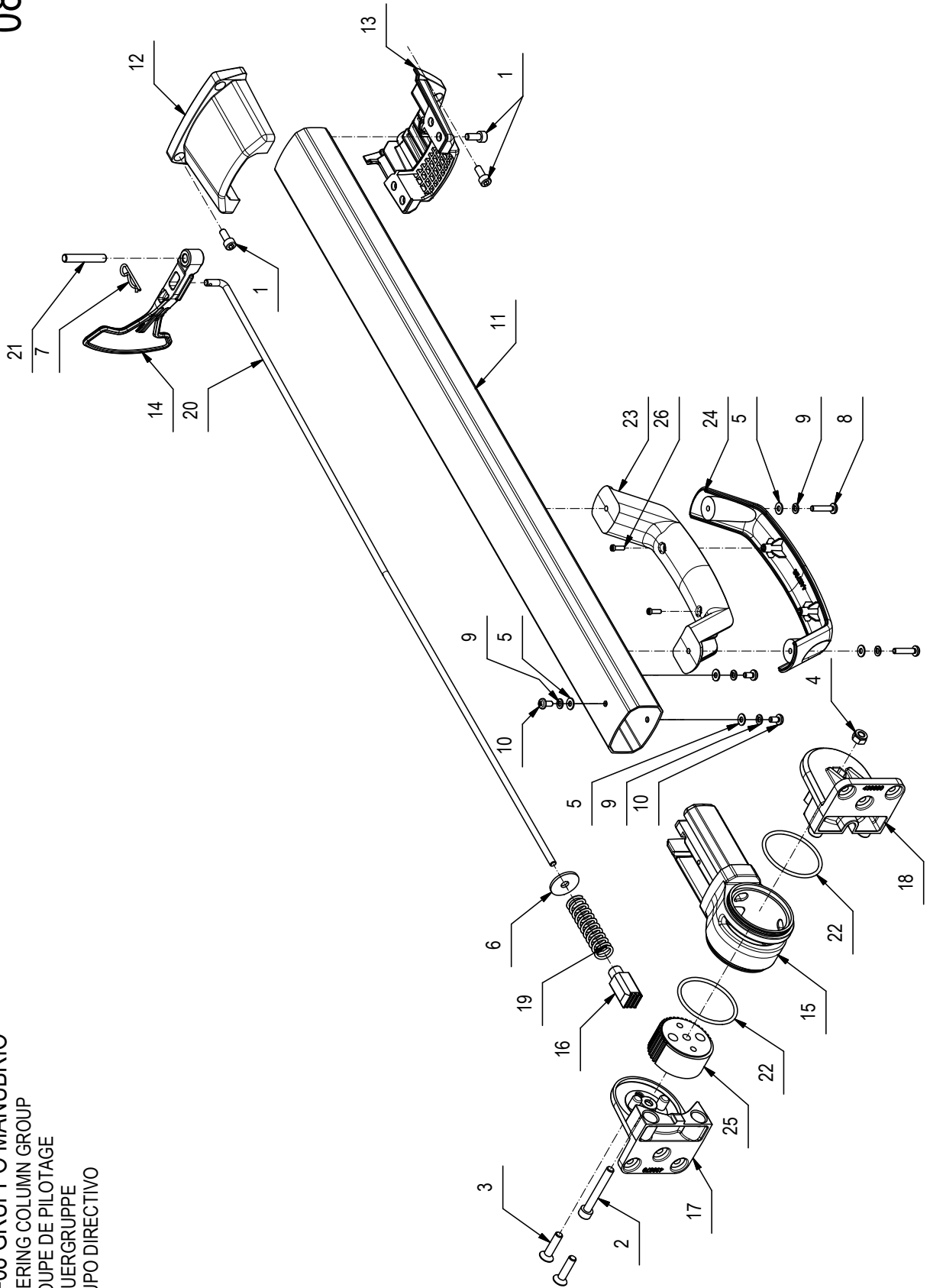

CR-08 GRUPPO MANUBRIO

08

POS	CODICE	QTÀ	DESCRIZIONE	DENOMINATION	DESCRIPTION	BENENNUNG	DESCRIPCION
1	408794	8	VITE M5X12 TCCE UNI 5931 INOX A2	SCREW	VIS	SCHRAUBE	TORNILLO
2	408807	1	VITE M6x45 TCEI UNI 5931 FP ZINC	SCREW	VIS	SCHRAUBE	TORNILLO
3	408972	2	VITE M6x25 TPSEI UNI 5933 A2	SCREW	VIS	SCHRAUBE	TORNILLO
4	409082	1	DADO M6x6 AUTOBL UNI 7474 ZINC	LOCK NUT	ECROU AUTOFREINES	SICHERUNGSMUTTER	TUERCA AUTOBLOCANTE
5	409142	5	ROSETTA 4x9x0,8 UNI 6592 ZINC	WASHER	RONDELLE	UNTERLAGSCHEIBE	ARANDELA
6	409162	1	ROSETTA 6,5x24x2 UNI 6593 ZINC	WASHER	RONDELLE	UNTERLAGSCHEIBE	ARANDELA
7	409394	1	SPILLO DIAM. 1.8X34	CLIP	EPINGLE	SPLINT	ESPIGA
8	415782	2	VITE M4X20 TCTC UNI 7687 ZINC	SCREW	VIS	SCHRAUBE	TORNILLO
9	415941	5	ROSETTA 4 UNI1751 ZINC GROWER	LOCK WASHER	RONDELLE FREIN	ZAHNSCHEIBE	ARANDELLA DENTADA
10	423644	3	VITE M4X8 TCTC UNI 7687 ZINC.	SCREW	VIS	SCHRAUBE	TORNILLO
11	439320	1	TUBO MANUBRIO COMPLETO	PIPE	TUBE	ROHR	TUBO
12	439855	1	CORPO ANTERIORE PADDLE	COVER	CARTER	ABDECKUNG	CARTER
13	439857	1	CORPO POSTERIORE PADDLE	COVER	CARTER	ABDECKUNG	CARTER
14	439859	1	LEVA PADDLE	LEVER	LEVIER	HEBEL	PALANCA
15	439877	1	CORPO SNODO	JOINT	JOINT	GELENK	ARTICULACION
16	439878	1	PERNO BLOCCO SNODO	JOINT	JOINT	GELENK	ARTICULACION
17	439879	1	SUPPORTO SNODO DX	SUPPORT	SUPPORT	HALTERUNG	SOPORTE
18	439880	1	SUPPORTO SX SNODO	JOINT	JOINT	GELENK	ARTICULACION
19	439926	1	MOLLA COMPRESSIONE 15x2x57	SPRING	RESSORT	FEDER	RESORTE
20	440081	1	ASTA SGANCIO MANUBRIO	ROD	TIGE	STANGE	VARILLA
21	440138	1	PERNO LEVA PADDLE	PIN	AXE	BOLZEN	PERNO
22	440139	2	GUARNIZIONE OR 3181	O-RING	JOINT	O-RING	JUNTA ANULAR
23	440725	1	MANIGLIA SOLLEVAMENTO INFERIORE	HANDLE	MANCHE	HANDGRIFF	MANILLA
24	440726	1	MANIGLIA SOLLEVAMENTO SUPERIORE	HANDLE	MANCHE	HANDGRIFF	MANILLA
25	440870	1	CORONA SNODO	CROWN GEAR	COURONNE	ZAHNKETTENRAD	CORONA DENTADA
26	440883	2	VITE UNI 9707-Pz-TZ D.3 x 10 ZINC.	SCREW	VIS	SCHRAUBE	TORNILLO

10049501-AA

09

CR-09 GRUPPO VOLANTE DI COMANDO

GROUP STEERING WHEEL CONTROL
 GROUPE DE CONTRÔLE DU VOLANT
 GROUP LENKRAD CONTROL
 GRUPO DE CONTROL VOLANTE

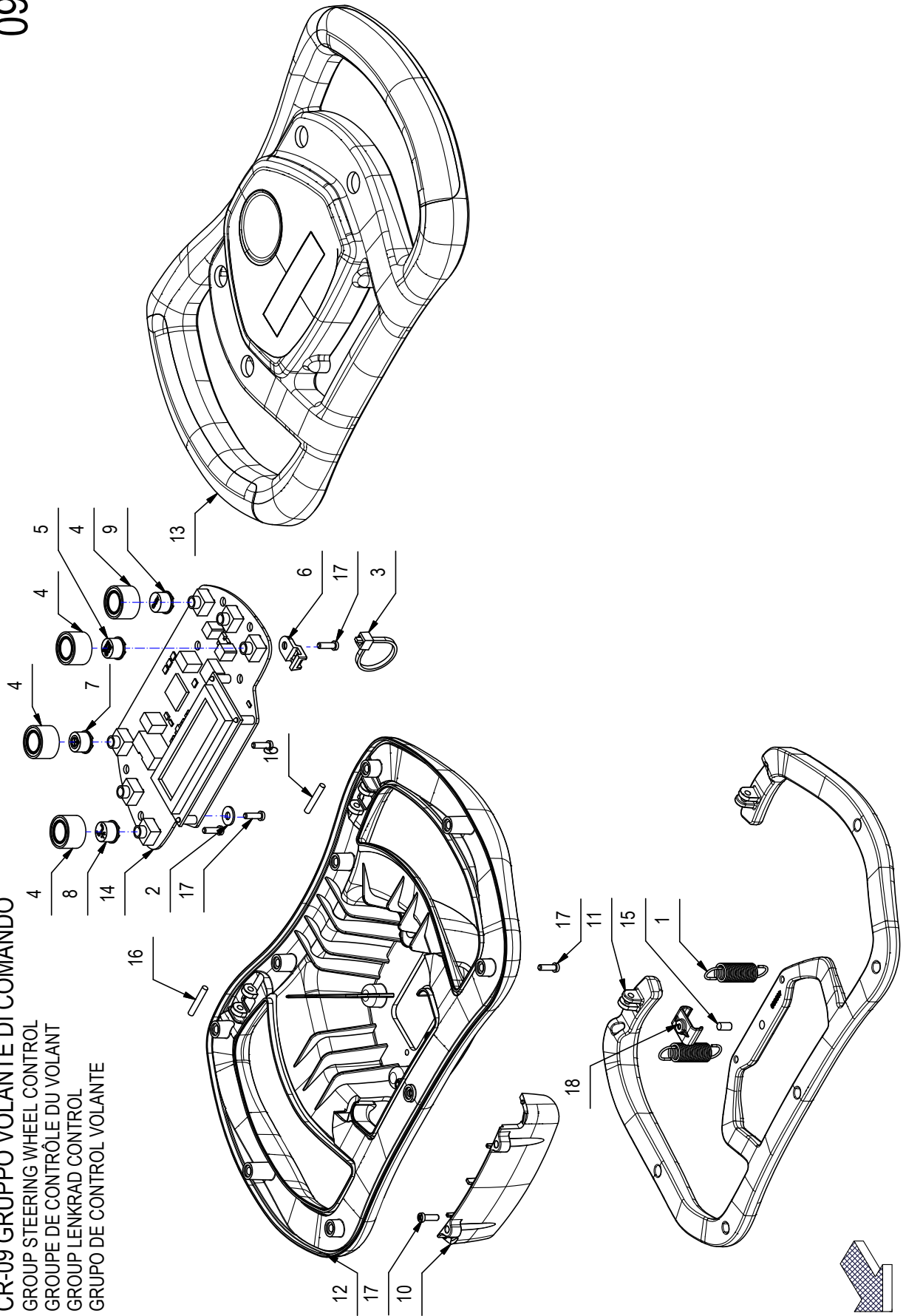

CR-09 GRUPPO VOLANTE DI COMANDO

09

POS	CODICE	QTÀ	DESCRIZIONE	DENOMINATION	DESCRIPTION	BENENNUNG	DESCRIPCION
1	408121	2	MOLLA TRAZ. 10x1.1x38 A2	SPRING	RESSORT	FEDER	RESORTE
2	409147	7	ROSETTA 4x10x1 NYLON	WASHER	RONDELLE	UNTERLAGSCHEIBE	ARANDELA
3	410274	1	FASCETTA PLASTICA 2.5x98	CLAMP	COLLIER	BRIDE	ABRAZADERA
4	436206	4	GHIERA SIGILLANTE MEC 1UW VOLANTE	GASKET	JOINT	DICHTUNG	JUNTA
5	436211	1	CAPPUCCIO VERDE RAL6018 MEC1US02 ECO M.	CAP	CAPUCHON	KAPPE	TAPON
6	436393	1	SUPPORTO AD OCCHIELLO D=4,1 (COD. 5461E)	SUPPORT	SUPPORT	HALTERUNG	SOPORTE
7	438071	1	CAPPUCCIO GRIGIO RAL7004 MEC1US03 ASPIR.	PROTECTION CAP	CALOTTE DE PROTECTION	SICHERHEITSKAPPE	CAPUCHO DE PROTECCION
8	438072	1	CAPPUCCIO GRIGIO RAL7004 MEC1US03 H2O+	PROTECTION CAP	CALOTTE DE PROTECTION	SICHERHEITSKAPPE	CAPUCHO DE PROTECCION
9	438073	1	CAPPUCCIO BLU MEC1US00 "AUTO"	PROTECTION CAP	CALOTTE DE PROTECTION	SICHERHEITSKAPPE	CAPUCHO DE PROTECCION
10	439854	1	CARTER CHIUSURA VOLANTE	COVER	CARTER	ABDECKUNG	CARTER
11	439860	1	LEVA PRESENZA UOMO	LEVER	LEVIER	HEBEL	PALANCA
12	439861	1	VOLANTE INFERIORE	COVER	CARTER	ABDECKUNG	CARTER
13	439862	1	VOLANTE SUPERIORE SOFT TOUCH	HANDLE BAR	TIMON	LENKSTANGE	MANILLAR
14	440029	1	SCHEDA COMANDI VOLANTE	CHECK CARD CONTROLS	PLAQUE CONTR. COMMANDES	KONTROLLEL. SCHALTUNGEN	FICHA CONTROL MANDOS
15	440060	1	MAGNETE NEODIMIO DN01.47 Ø4x7	MAGNET	AIMANT	MAGNET	IMAN
16	440410	2	SPINA CILINDRICA Ø3x20 UNI 22338-B	SPRING PIN	FOURCHETTE	SPANNSTIFT	PASADOR ELASTICO
17	440883	22	VITE UNI 9707-Pz-TZ D.3 x 10 ZINC.	SCREW	VIS	SCHRAUBE	TORNILLO
18	441788	1	FERMO MAGNETE PRESENZA UOMO	STOP	ARRET	STOPBELEG	PLAQUETA DE SUJECION

NOTE

A large rectangular area consisting of approximately 30 horizontal lines for writing notes.



COMAC S.p.A. - Via Maestri del Lavoro, 13 - 37059 S. Maria di Zevio - Verona - Italy
Tel. +39 045 8774222 - Fax +39 045 8750303 - E-mail: com@comac.it
www.comac.it