

FM400 L

Model:
FM400 L

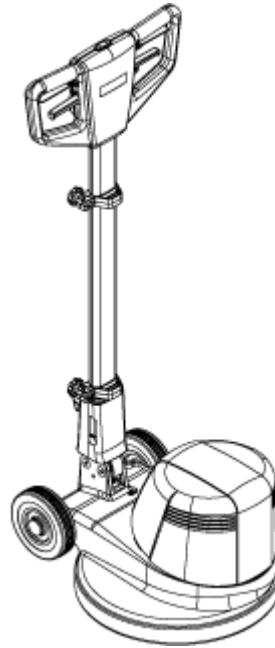

Part List US-English

05-04-2015

Table of Contents

FM400 L

Base system FM400L	3
Handle system	6
Wiring and recommended spare parts	9
Brush selector guide	12
Accessories	14
Solution tank kit 10104A	16
Foam generator kit 11294A	18
Spray buff kit 11295A	20
Dust collection kit 56381571	22

Base system FM400L

FM400 L

05-04-2015

Part List ID
FM40002

3

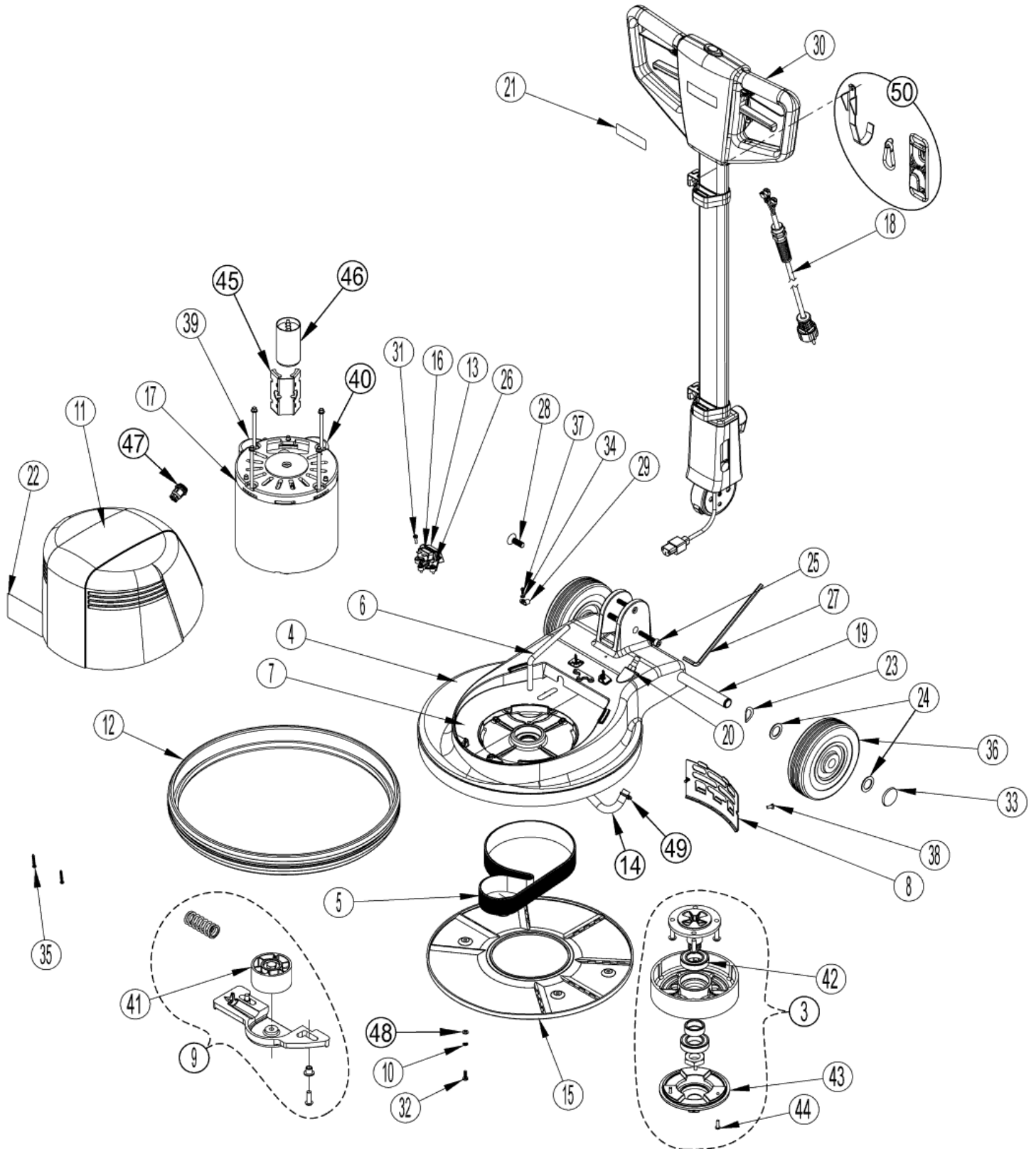

Base system FM400L

FM400 L

05-04-2015

Part List ID
F-M40002

4

Pos	Part no.	Qty	Description	
3	56380089	1	SPINDLE ASM	Contains item 42,43,44
4	56380093	1	MAINFRAME NILFISK FM400	
5	56380104	1	BELT POLY V 838 PJ16	
6		1	NOTE COMMENT	Inlet Tubing
7	56381565	1	COOLING PLATE	
8	56381566	1	BACK COVER	
9	56381579	1	BELT TENSION ASM	
10		4	NOTE COMMENT	Washer M5 Helical Lock
11		1	NOTE COMMENT	Cover Motor Asm
12	30272A	1	BUMPER	
13		1	NOTE COMMENT	Mount Inlet
14		1	NOTE COMMENT	Hose Solution
15		1	NOTE COMMENT	Cover Bottom
16		1	NOTE COMMENT	Inlet IEC 60320 C14
17	40258A	1	MOTOR LOW SPEED	
18	40249A	1	CORD POWER UK	
18	40268A	1	CORD POWER	
19	61956A	1	SHAFT WHEEL	
20		1	NOTE COMMENT	Hosebarb Straight
21		1	NOTE COMMENT	Label Handle Nilfi sk
22		1	NOTE COMMENT	Label Cover Motor FM400
23		2	NOTE COMMENT	Washer Bowed 20mm
24		4	NOTE COMMENT	Washer Flat 20mm
25		2	NOTE COMMENT	Screw M8 - 1 X 45 Socket Recess
26		2	NOTE COMMENT	Screw St4.2-1.4 X16 Ss Truss Hd Ph
27		1	NOTE COMMENT	Wrench Allen 6mm
28		2	NOTE COMMENT	Screw M10-1.5 X 30 Flat Head
29		1	NOTE COMMENT	Clamp-1/4 Cable/Tubing
30	56382011	1	NILFISK HANDLE ASM W/CEE 7/7	(includes #18 / PN 40268A)
30	56382012	1	NILFISK HANDLE ASM W/BS-1363	(includes #18 / PN 40249A)
31		3	NOTE COMMENT	Scr, M4.7x16mm Pan Cross Recess Thd Form
32		4	NOTE COMMENT	Screw M5-.8 X 16
33		2	NOTE COMMENT	Wheel Retainer
34		1	NOTE COMMENT	Washer External Tooth M4
35		4	NOTE COMMENT	Screw St4-1.4 X 30 Pan Head
36		2	NOTE COMMENT	Wheel 160mm Dia. Gray
37		1	NOTE COMMENT	Scr M4 X 10 SS Pan Cross Recess
38	GT13054	2	SCREW PAN HEAD M5X12	
39	VF32109	1	RUNNING CAPACITOR 20UF/600V	
40	VF999849	1	START CAPACITOR 100F/300V	
41	56380090	1	FLAT IDLER ASM	
42	VF14061	1	BEARING 6006	
43	56380099	1	DRIVER	

Base system FM400L

FM400 L

05-04-2015

Part List ID

F-M40002

5

Pos	Part no.	Qty	Description	
44	56381538	3	SCR M5-.8X16 BTN HD SS	
48		4	NOTE COMMENT	Washer M5 X 12
49		1	NOTE COMMENT	Hose Clamp 10MM
50	56382010	1	CONVENIENCE KIT	
K1	11282A	2	WHEEL KIT	POS. 23, 24, 33, 36
K2	11287A	1	DECAL KIT NILFISK	POS. 21, 22
K3	56381563	1	NILFISK MOTOR COVER KIT	POS. 11, 35
K5	56382001	1	INSTALLATION TOOL AND HARDWARE KIT	POS. 27, 28, 29, 37
K6	56380089	1	SPINDLE ASM	POS. 3, 42, 43, 44 - TSB-FC-2013-108
K8	11267A	1	BOTTOM COVER KIT	POS. 10, 15, 32
K9	11283A	1	INLET KIT	POS. 13, 16, 26, 31
K10	56381579	1	BELT TENSION ASM	POS. 9, 41

Handle system

FM400 L

05-04-2015

Part List ID
FM40004

6

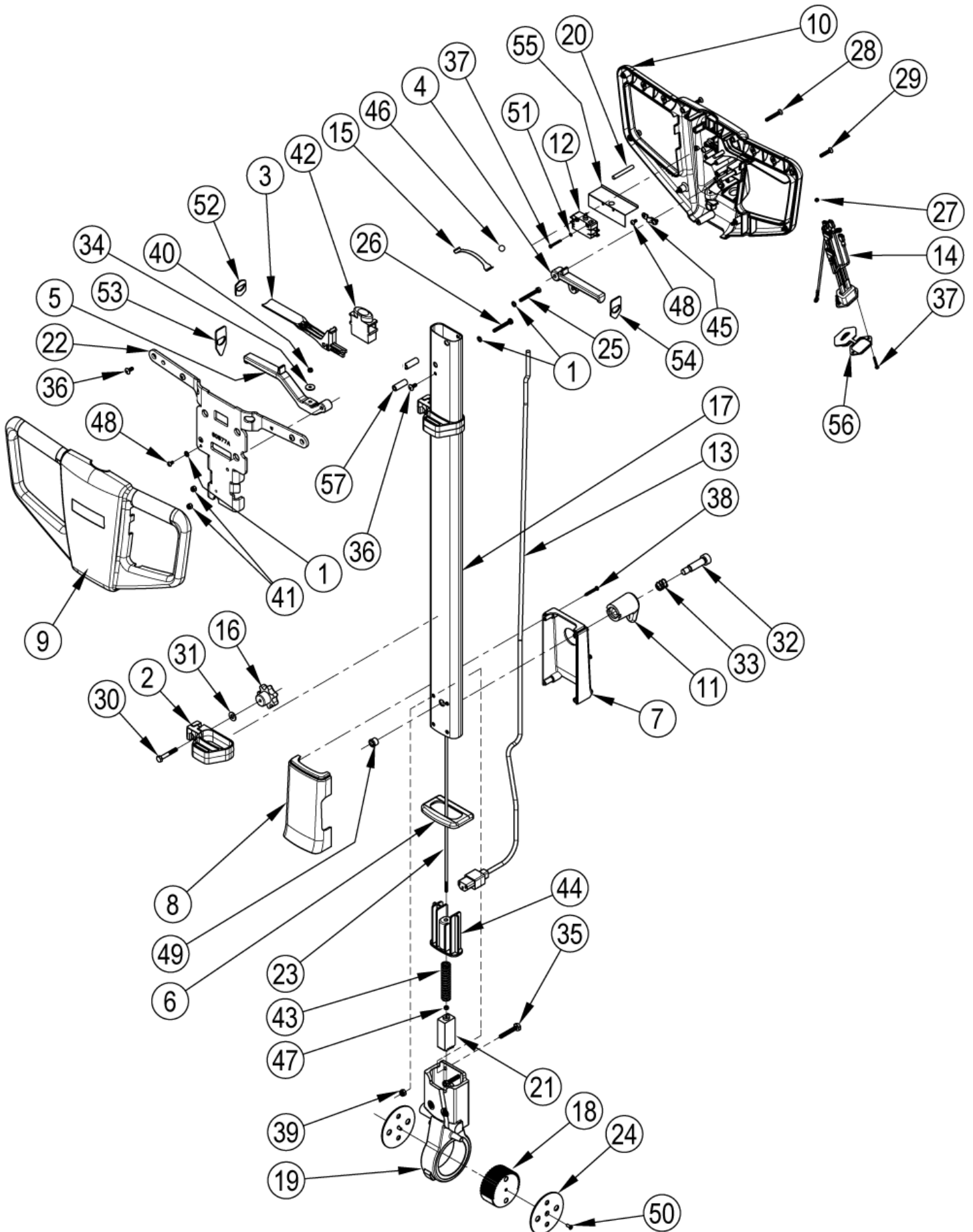

Handle system

FM400 L

05-04-2015

Part List ID

F-M40004

7

Pos	Part no.	Qty	Description	
1		3	NOTE COMMENT	WASHER SH 1210-00
2		2	NOTE COMMENT	ACCESSORY CLAMP
3		2	NOTE COMMENT	LEVER SWITCH
4		1	NOTE COMMENT	LEVER SOLUTION
5		1	NOTE COMMENT	LEVER HANDLE ADJUSTMENT
6		1	NOTE COMMENT	CAP RUBBER
7		1	NOTE COMMENT	COVER REAR
8		1	NOTE COMMENT	COVER FRONT
9		1	NOTE COMMENT	COVER HANDLE FRONT
10		1	NOTE COMMENT	COVER HANDLE REAR
11		1	NOTE COMMENT	HOOK CORD
12	40263A	1	SWITCH DPST	
13	40269A	1	INTERCONNECT CORD	
14		1	NOTE COMMENT	OUTLET / WIRING ASSEMBLY
15		1	NOTE COMMENT	SPRING INTERLOCK BUTTON
16		2	NOTE COMMENT	KNOB CLAMP M6
17		1	NOTE COMMENT	TUBE HANDLE
18		1	NOTE COMMENT	INDEX GEAR
19		1	NOTE COMMENT	HANDLE MOUNT
20		4	NOTE COMMENT	PIN HANDLE SUPPORT
21		1	NOTE COMMENT	PLUNGER
22		1	NOTE COMMENT	HANDLE SUPPORT
23		1	NOTE COMMENT	ROD INDEX
24		2	NOTE COMMENT	PLATE, GEAR HOUSING
25		1	NOTE COMMENT	SCREW M5 X 43 SS HEX HEAD
26		1	NOTE COMMENT	SCREW M5 X 40 SS PAN HEAD PHILLIPS
27		2	NOTE COMMENT	NUT HEX M3-0.5 SS
28		2	NOTE COMMENT	SCREW M5 X 35 SS FLAT HEAD PHILLIPS
29		6	NOTE COMMENT	SCREW M5 X 25 SS FLAT HEAD PHILLIPS
30		2	NOTE COMMENT	SCR M6-1 X40 HEX SS
31		2	NOTE COMMENT	WASHER FLAT 6.6X15.8X1.5 SS
32		1	NOTE COMMENT	SCR SHOULDER 12MM X 35MM, M10-1.5
33		1	NOTE COMMENT	SPRING 15 MM X 15 MM LONG
34		1	NOTE COMMENT	WASHER M4 X16
35		4	NOTE COMMENT	SCREW M6 X 40 SS HEX HEAD
36		5	NOTE COMMENT	SCREW M5 X 12 SS TRUSS HEAD PHILLIPS
37		4	NOTE COMMENT	SCREW M3 X 25 SS PAN HEAD PHILLIPS
38		4	NOTE COMMENT	SCREW ST4-1.4 X 30 PAN HEAD1
39		4	NOTE COMMENT	NUT M6 SS NYLON INSERT
40		1	NOTE COMMENT	NUT M4 SS NYLON INSERT
41		2	NOTE COMMENT	NUT M5 SS NYLON INSERT
42		1	NOTE COMMENT	BUTTON INTERLOCK
43		1	NOTE COMMENT	SPRING COMPRESSION

Handle system

FM400 L

05-04-2015

Part List ID
F-M40004

8

Pos	Part no.	Qty	Description	
44		1	NOTE COMMENT	HOUSING SPRING BLACK
45		1	NOTE COMMENT	CLAMP CORD
46		1	NOTE COMMENT	BALL INTERLOCK 10MM
47		1	NOTE COMMENT	NUT M4 SS JAM
48		4	NOTE COMMENT	SCREW, M4 X 8 SS PAN HEAD PHILLIPS
49		1	NOTE COMMENT	BUSHING-OPEN/CLOSED .50
50		2	NOTE COMMENT	SCR M4-.7 X 10MM FLT PHILLIPS
51		2	NOTE COMMENT	WASHER M3 EXTERNAL TOOTH
52		2	NOTE COMMENT	SWITCH LEVER SEAL
53		1	NOTE COMMENT	RELEASE LEVER SEAL
54		1	NOTE COMMENT	ACCESSORY LEVER SEAL
55		1	NOTE COMMENT	SWITCH DRIP GUARD
56	VF73708	1	WATERPROOF CAP	
57		2	NOTE COMMENT	SUPPORT HANDLE TUBE
K1	11269A	1	CORD WRAP KIT	POS. 11, 12, 13, 32, 33
K2	11280A	1	HANDLE COVER KIT	POS. 9, 10, 28, 29
K3	11273A	1	HANDLE SUPPORT KIT	POS. 1, 22, 25, 26, 36, 41
K4	11274A	1	HANDLE SWITCH LEVER KIT	POS. 3, 4, 5, 15, 20, 34, 37,40,42 45, 46, 48, 51,
K5	11286A	1	RELEASE SPRING AND ROD KIT	POS. 23, 34, 40, 43, 47
K6	56381560	1	POLISHER GEAR SET KIT	POS. 18, 19, 21, 24, 50
K7	56381561	1	POLISHER GEAR HOUSING AND TUBE KIT	POS. 17, 19, 35, 39, 44
K8	11270A	1	OUTLET KIT	POS. 14, 27, 37
K9	11268A	2	MOUNT ACCESSORY KIT	POS. 2, 16, 30, 31
K10	11271A	1	REAR AND FRONT COVER KIT	POS. 6, 7, 8, 38, 49

Wiring and recommended spare parts

FM400 L

05-04-2015

Part List ID
FM40010

9

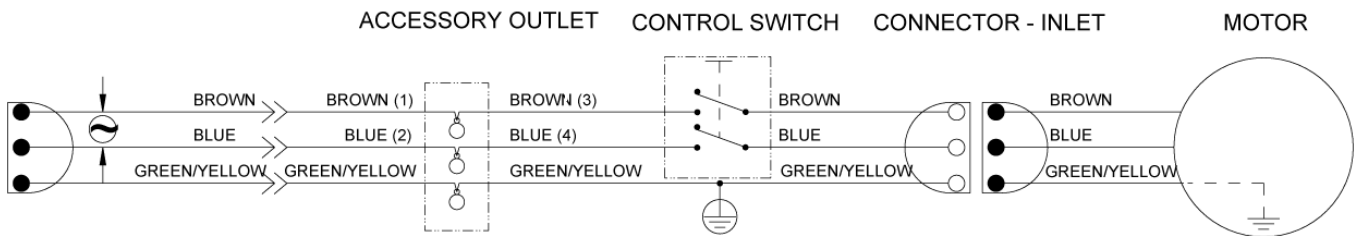

MOTOR DIAGRAM

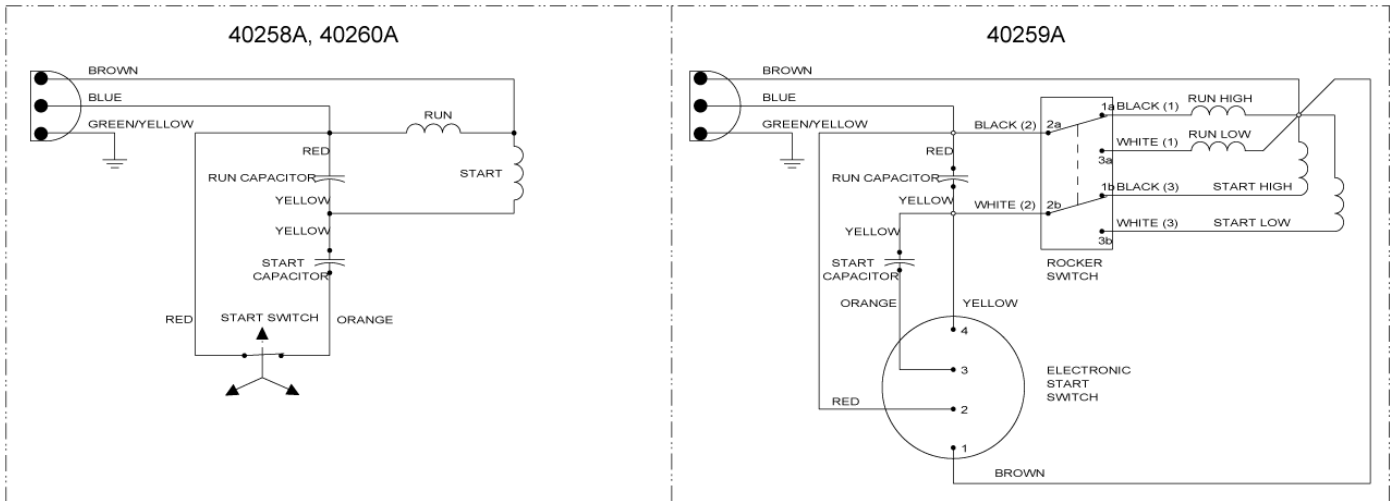

Wiring and recommended spare parts

FM400 L

05-04-2015

Part List ID
F-M40010

10

Pos	Part no.	Qty	Description	
B	11267A	1	BOTTOM COVER KIT	EM
B	11282A	1	WHEEL KIT	EM
B	11283A	1	INLET KIT	EM
B	11284A	1	SOLUTION FITTINGS KIT	EM
B	11287A	1	DECAL KIT NILFISK	EM
B	11288A	1	NILFISK ALTO DS MOTOR COVER KIT	EM
B	30272A	1	BUMPER	OM
B	40258A	1	MOTOR LOW SPEED	EM
B	40259A	1	MOTOR DUAL SPEED	EM
B	40260A	1	MOTOR HIGH SPEED	EM
B	40264A	1	SWITCH ROCKER ON-ON	OM
B	47378A	1	SWITCH MOTOR STARTING CLASSI	OM
B	56380089	1	SPINDLE ASM	EM-TSB-FC-2013-108
B	56380090	1	FLAT IDLER ASM	OM
B	56380093	1	MAINFRAME NILFISK FM400	EM
B	56380094	1	MAINFRAME NILFISK FM400 D	EM
B	56380099	1	DRIVER	OM
B	56380104	1	BELT POLY V 838 PJ16	OM
B	56381562	1	SADDLE START SWITCH	EM
B	56381563	1	NILFISK MOTOR COVER KIT	EM
B	56381564	1	NILFISK DS MOTOR COVER KIT	EM
B	56381565	1	COOLING PLATE	EM
B	56381566	1	BACK COVER	EM
B	56381579	1	BELT TENSION ASM	EM
B	61956A	1	SHAFT WHEEL	EM
B	GT17003	1	CAPACITOR	OM FM400 H, FM400 H UK
B	GT17004	1	CAPACITOR	OM FM400 D, FM400 D UK
B	VF14061	1	BEARING 6006	OM
B	VF32109	1	RUNNING CAPACITOR 20UF/600V	OM FM400 L, FM400 L UK
B	VF999848	1	RUN CAPACITOR 23F/500V	OM FM400 H, FM400 H UK, FM400 D, FM400 D UK
B	VF999849	1	START CAPACITOR 100F/300V	OM FM400 L, FM400 L UK
F	40249A	1	CORD POWER UK	EM
F	40268A	1	CORD POWER	EM
F	56382010	1	CONVENIENCE KIT	EM
F	56382011	1	NILFISK HANDLE ASM W/CEE 7/7	EM (includes PN 40268A)
F	56382012	1	NILFISK HANDLE ASM W/BS-1363	EM (includes PN 40249A)
H	11268A	2	MOUNT ACCESSORY KIT	OM
H	11269A	1	CORD WRAP KIT	EM
H	11270A	1	OUTLET KIT	EM
H	11271A	1	REAR AND FRONT COVER KIT	EM
H	11273A	1	HANDLE SUPPORT KIT	EM
H	11274A	1	HANDLE SWITCH LEVER KIT	OM

Pos. B = Base system, Pos. F = Final assembly, Pos. H = Handle assembly

Commet - Class:

W = Normal Wear

OM = Ordinary Maintenance

Wiring and recommended spare parts

FM400 L

05-04-2015

Part List ID

F-M40010

11

Pos	Part no.	Qty	Description	
H	11280A	1	HANDLE COVER KIT	EM
H	11286A	1	RELEASE SPRING AND ROD KIT	EM
H	40263A	1	SWITCH DPST	OM
H	40269A	1	INTERCONNECT CORD	EM
H	56381560	1	POLISHER GEAR SET KIT	EM
H	56381561	1	POLISHER GEAR HOUSING AND TUBE KIT	EM
H	VF73708	1	WATERPROOF CAP	EM

Pos. B = Base system, Pos. F = Final assembly, Pos. H = Handle assembly

Commet - Class:

W = Normal Wear

OM = Ordinary Maintenance

Brush selector guide

FM400 L

05-04-2015

Part List ID
FM40014

12

BRUSH SELECTOR GUIDE

Part No.	Description	Filament	Trim
11296A	Polishing	Union Mix (50% PALMYRA 50% White Tampico)	Straight
11297A	Carpet	Ø .30mm PA 66 Natural	Straight
11298A	Light-Medium Cleaning	Ø .35mm PP Grey	Straight
11299A	Medium-Heavy Cleaning	Ø .50mm PP Black	Straight
11310A	Heavy Cleaning/ Stripping	50/80/30 Silicon Carbide	Irregular

Description	P/N	56380056 FM400 L	56380057 FM400 L UK	56380058 FM400 H	56380060 FM400 H UK	56380061 FM400 D	56380062 FM400 D UK
Polishing Brush	11296A			X	X	X	X
Carpet Brush	11297A	X	X				
Light-Medium Cleaning Brush	11298A	X	X			X	X
Medium Cleaning Brush	11299A	X	X			X	X
Heavy Cleaning/Stripping Brush	11310A	X	X			X	X
Brush-Shampoo Commercial Crpt	56383868	X	X				
Pad Driver-Low Speed-430 MM	11315A	X	X			X	X
Pad Driver-High Speed-Flex	11316A			X	X	X	X
Pad Driver-High SP-Flex-Foam	56381578			X	X	X	X
BLACK 406mm PAD 5 PK		X	X			X	X
BROWN 406mm PAD 5 PK		X	X			X	X
GREEN 406mm PAD 5 PK		X	X			X	X
BLUE 406mm PAD 5 PK		X	X			X	X
RED 406mm PAD 5 PK		X	X	X	X	X	X
WHITE 406mm PAD 5 PK		X	X	X	X	X	X

Black – Stripping – For long lasting, heavy duty stripping.

Brown – Stripping – For fast, uniform stripping, wet or dry.

Green – Scrubbing – For wet, heavy duty scrubbing.

Blue – Scrubbing – For wet, medium duty scrubbing.

Red – Buffing – For dry buffing, spray buffing or light duty scrubbing.

White – Polishing – For dry polishing or with the water mist to ensure high gloss.

Brush selector guide

FM400 L

05-04-2015

Part List ID

F-M40014

13

Pos	Part no.	Qty	Description
1	11296A	1	POLISHING BRUSH 430MM
2	56382022	1	FM400 L SHAMPOO BRUSH
3	11298A	1	LIGHT-MEDIUM CLEANING BRUSH 430MM
4	11299A	1	MEDIUM-HEAVY CLEANING BRUSH 430MM
5	11310A	1	HEAVY CLEANING STRIPPING BRUSH 430MM
10	11315A	1	PAD DRIVER-LOW SPEED-430 MM
11	11316A	1	PAD DRIVER-HIGH SPEED-FLEX
12	56381578	1	PAD DRIVER-HIGH SP-FLEX-FOAM
20		1	PAD 16 406MM ECO BLACK 5PCS
21		1	PAD 16 406MM GREEN 5PCS
22		1	PAD 16 406MM ECO WHITE 5PCS
23		1	PAD 16 406MM ECO RED 5PCS
24		1	PAD 16 406MM BLUE 5PCS
25		1	PAD 16 406MM ECO BROWN 5PCS

Accessories

FM400 L

05-04-2015

Part List ID
FM44016

14

Description	P/N	56380056 FM400 L	56380057 FM400 L UK	56380058 FM400 H	56380060 FM400 H UK	56380061 FM400 D	56380062 FM400 D UK
Literature Pack	56044439	X	X	X	X	X	X
(1) Solution Tank Kit*	10104A	X	X			X	X
(2) Foam Generator Kit*	11294A	X	X				
(3) Spray Buff Kit*	11295A	X	X	X	X	X	X
(4) Dust Collection Kit*	56381571			X	X	X	X

* = Optional, Not Included

NOTE = Replacement parts for the kits listed above (1-4) can be found on each kit's associated instruction sheet.

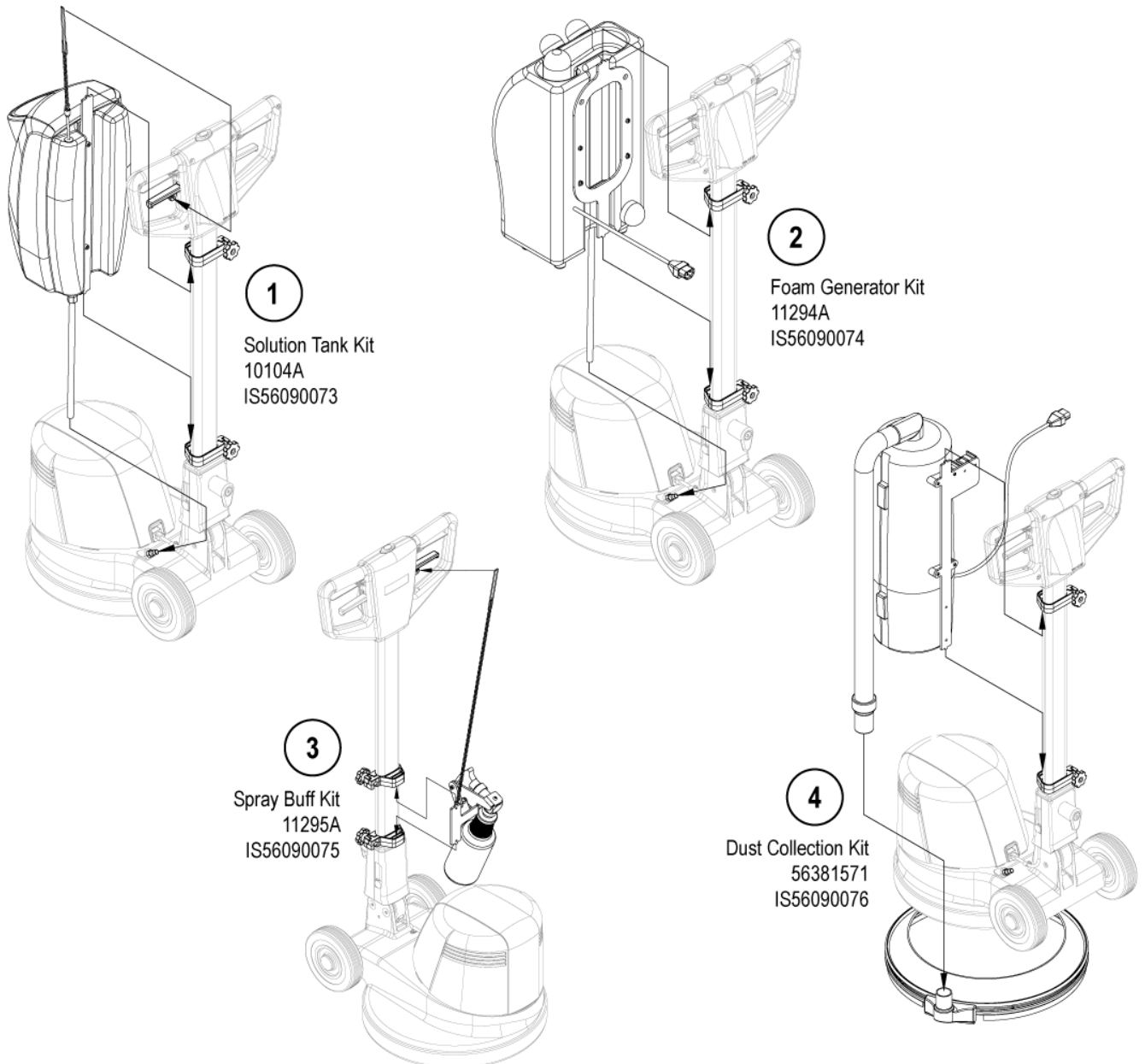

Accessories

FM400 L

05-04-2015

Part List ID
F-M44016

15

Pos	Part no.	Qty	Description
1	10104A	1	SOLUTION TANK ACC KIT
2	11294A	1	FOAM GENERATOR KIT
3	11295A	1	SPRAY BUFF KIT
4	56381571	1	DUST COLLECTION KIT

Solution tank kit 10104A

FM400 L

05-04-2015

Part List ID

56090073

16

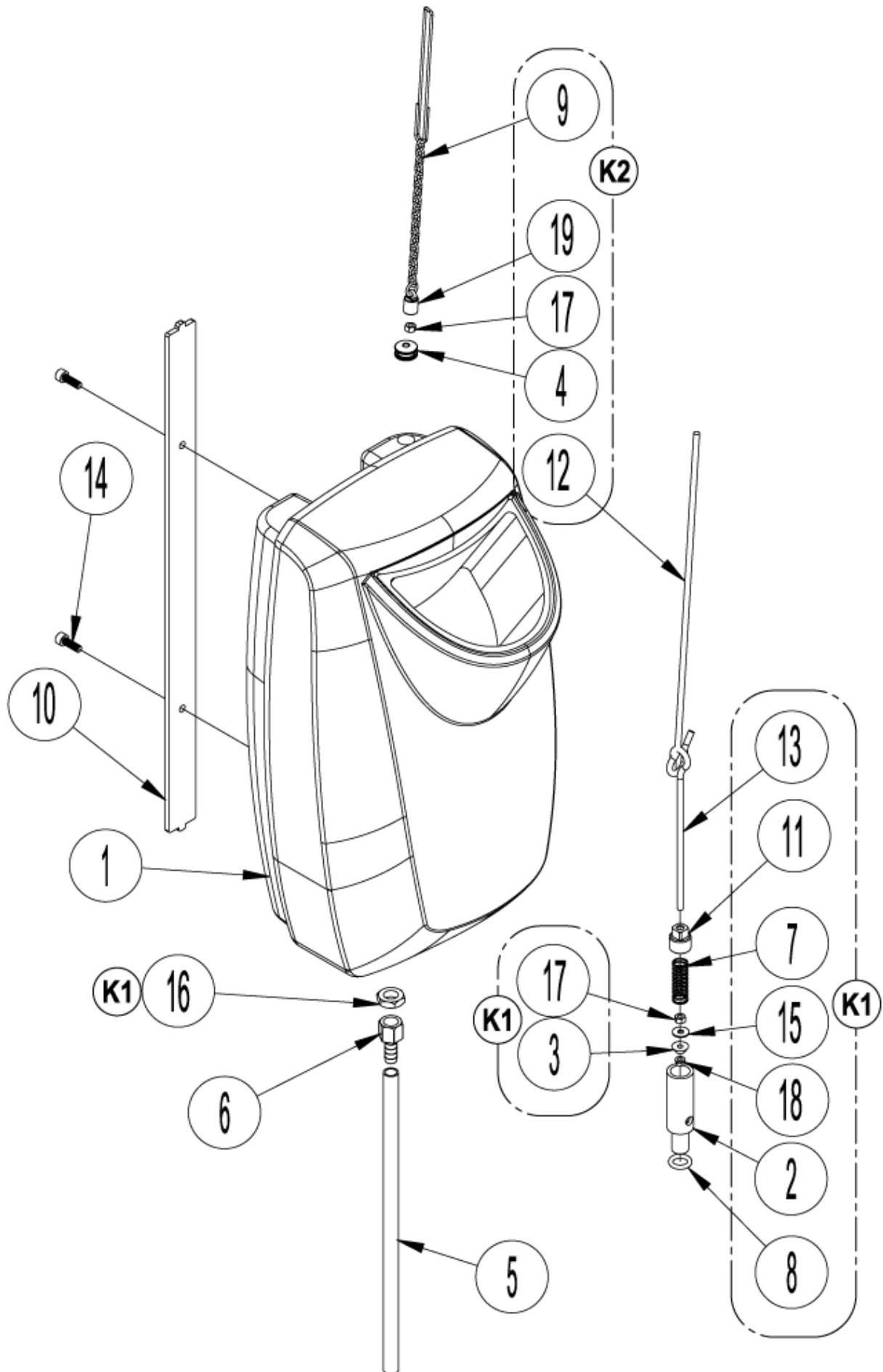

Solution tank kit 10104A

FM400 L

05-04-2015

Part List ID
56090073

17

Pos	Part no.	Qty	Description
0	10104A	1	SOLUTION TANK ACC KIT
1	30249A	1	TANK SOLUTION
2		1	NOTE COMMENT BODY VALVE PLASTIC
3	VF40134	1	SEAL RUBBER
4		1	NOTE COMMENT SEAL
5	30869A	1	TUBING VINYL
7		1	NOTE COMMENT SPRING COMPRESSION S.S.
8		1	NOTE COMMENT O-RING
9		1	NOTE COMMENT CHAIN ASM
10	60023A	1	BRACKET MOUNTING SOLUTION TANK
11		1	NOTE COMMENT BONNET M18X1.5 NYLON
12		1	NOTE COMMENT ROD UPPER PULLING BRASS
13		1	NOTE COMMENT ROD LOWER PULLING BRASS
14	VF13498	2	SCREW M6X20
15		1	NOTE COMMENT WASHER, PLAIN 5MM BRASS
16		1	NOTE COMMENT NUT HEX M14X1.5 BRASS
17		2	NOTE COMMENT NUT HEX M5X0.8 BRASS
18		1	NOTE COMMENT NUT HEX FLANGED M5X0.8 BRASS
19		1	NOTE COMMENT NUT EYE M5
K1	11278A	1	SOLUTION VALVE ASSEMBLY
K2	11277A	1	SOLUTION TANK UPPER HARDWARE KIT

Foam generator kit 11294A

FM400 L

05-04-2015

Part List ID
56090074

18

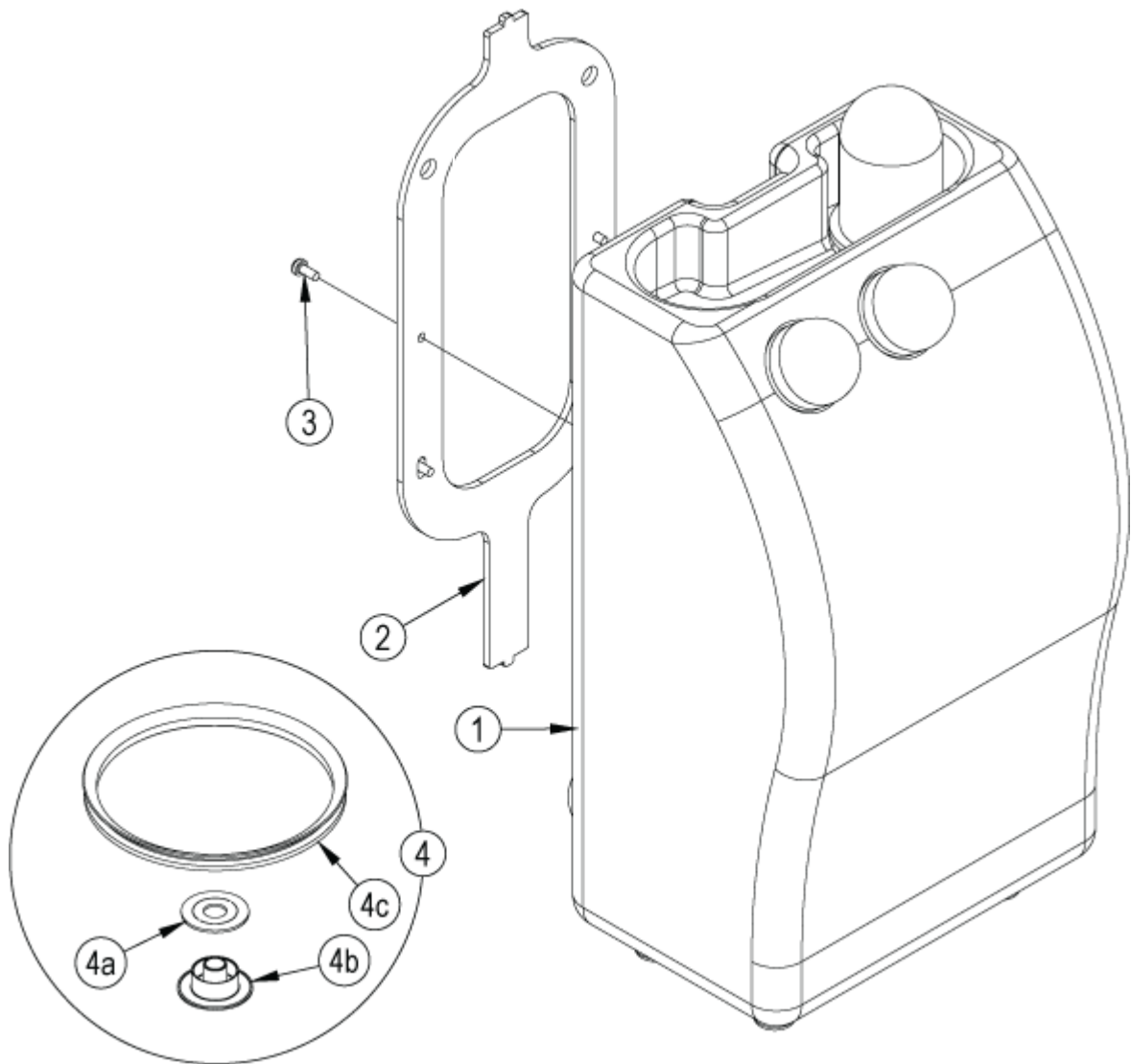

Foam generator kit 11294A

FM400 L

05-04-2015

Part List ID
56090074

19

Pos	Part no.	Qty	Description	
0	11294A	1	FOAM GENERATOR KIT	
1		1	NOTE COMMENT	Foam Generator
2	60459A	1	BRACKET FOAM GENERATOR MOUNTING	
3		1	NOTE COMMENT	Scr M5- .8 X 16 Fil Cross Rec
4	56382020	1	FM400 L SEAL KIT FOR CARPET APPLICATION	
SP	VF14227	1	O-RING	SERVICE PARTS
SP	VF46404	1	KIT TANK KNOB INTAKE	SERVICE PARTS
SP	VF46422-6	1	MICRO SWITCH	SERVICE PARTS
SP	VF46422-8	1	VALVE BODY	SERVICE PARTS
SP	VF46435	1	FILTER OUTLET TANK	SERVICE PARTS
SP	VF46454	1	FILTER INTAKE TANK	SERVICE PARTS
SP	VF46468	1	FAN	SERVICE PARTS
SP	YQ11000	1	PUMP	SERVICE PARTS

Spray buff kit 11295A

FM400 L

05-04-2015

Part List ID
56090075

20

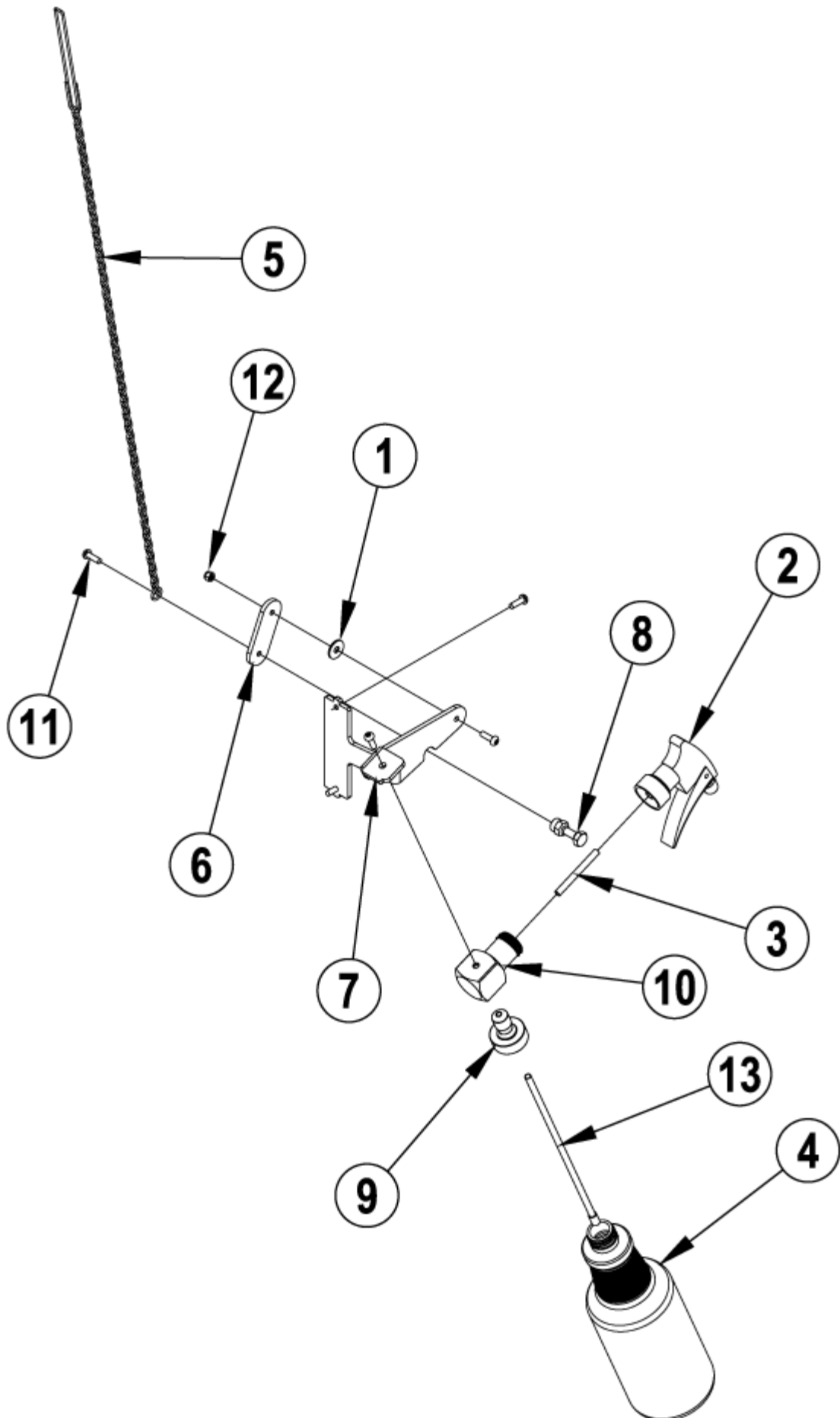

Spray buff kit 11295A

FM400 L

05-04-2015

Part List ID
56090075

21

Pos	Part no.	Qty	Description
0	11295A	1	SPRAY BUFF KIT
1		1	NOTE COMMENT Washerfl t.750x.250x.062Nylon
2		1	NOTE COMMENT Spray Buff Pump
3		1	NOTE COMMENT Tube
4		1	NOTE COMMENT Bottle Plastic Quart Carafe
5		1	NOTE COMMENT Chain Asm
6		1	NOTE COMMENT Link Spray Buff
7		1	NOTE COMMENT Bracket Spray Buff
8		1	NOTE COMMENT Actuator
9		1	NOTE COMMENT Mount
10		1	NOTE COMMENT Adaptor
11		5	SCREW M5 X 16
12		1	NOTE COMMENT Nut M5 Ss Nylon Insert
13		1	NOTE COMMENT Tube Dip
K1	56382005	1	SPRAY BUFF REPAIR KIT Includes pos. 2,3,4,5,8,11,13

Dust collection kit 56381571

FM400 L

05-04-2015

Part List ID
56090076

22

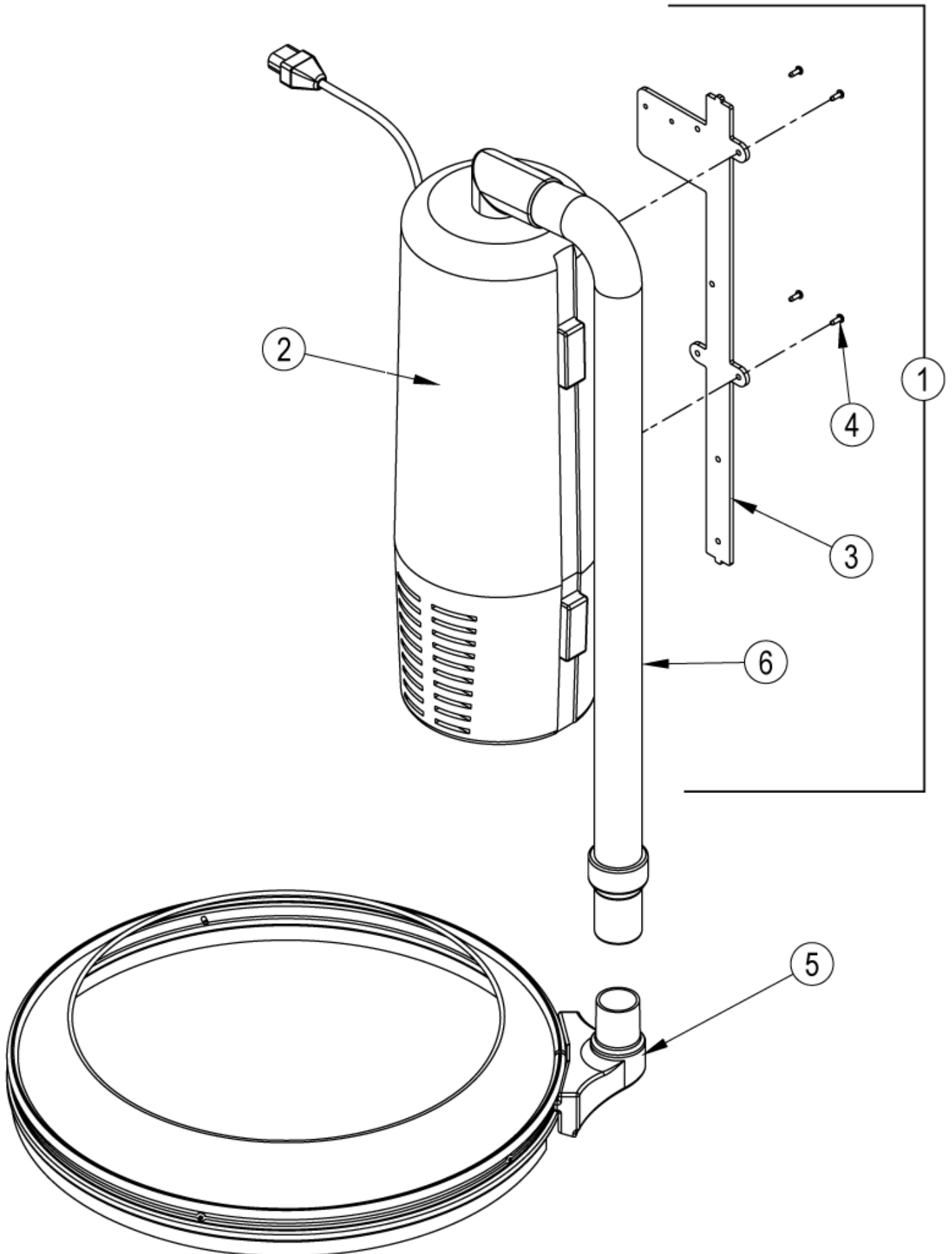

Dust collection kit 56381571

FM400 L

05-04-2015

Part List ID
56090076

23

Pos	Part no.	Qty	Description
0	56381571	1	DUST COLLECTION KIT
1		1	NOTE COMMENT Dust Control Assy NOTE 1
2		1	NOTE COMMENT Vacuum Assembly
3		1	NOTE COMMENT Bracket
4		4	NOTE COMMENT Screw M4-1.79 x 20mm
5	10394A	1	DUST SKIRT ASM
6	147 1237 500	1	HOSE CPL.L1250
NI	147 1098 500	1	DUST BAG KIT 5L 5-PCS

NOTE 1: Refer to the GD 5, GD 10, GD 5 Battery parts list for Dust Control Assy replacement parts.